

Perspective View

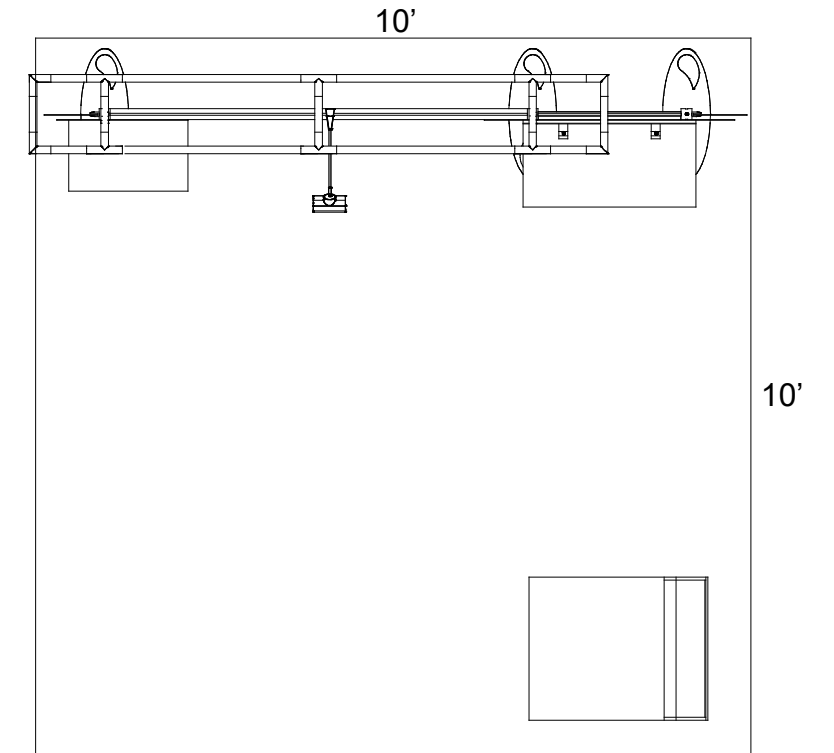

Plan View

SETUP INSTRUCTIONS

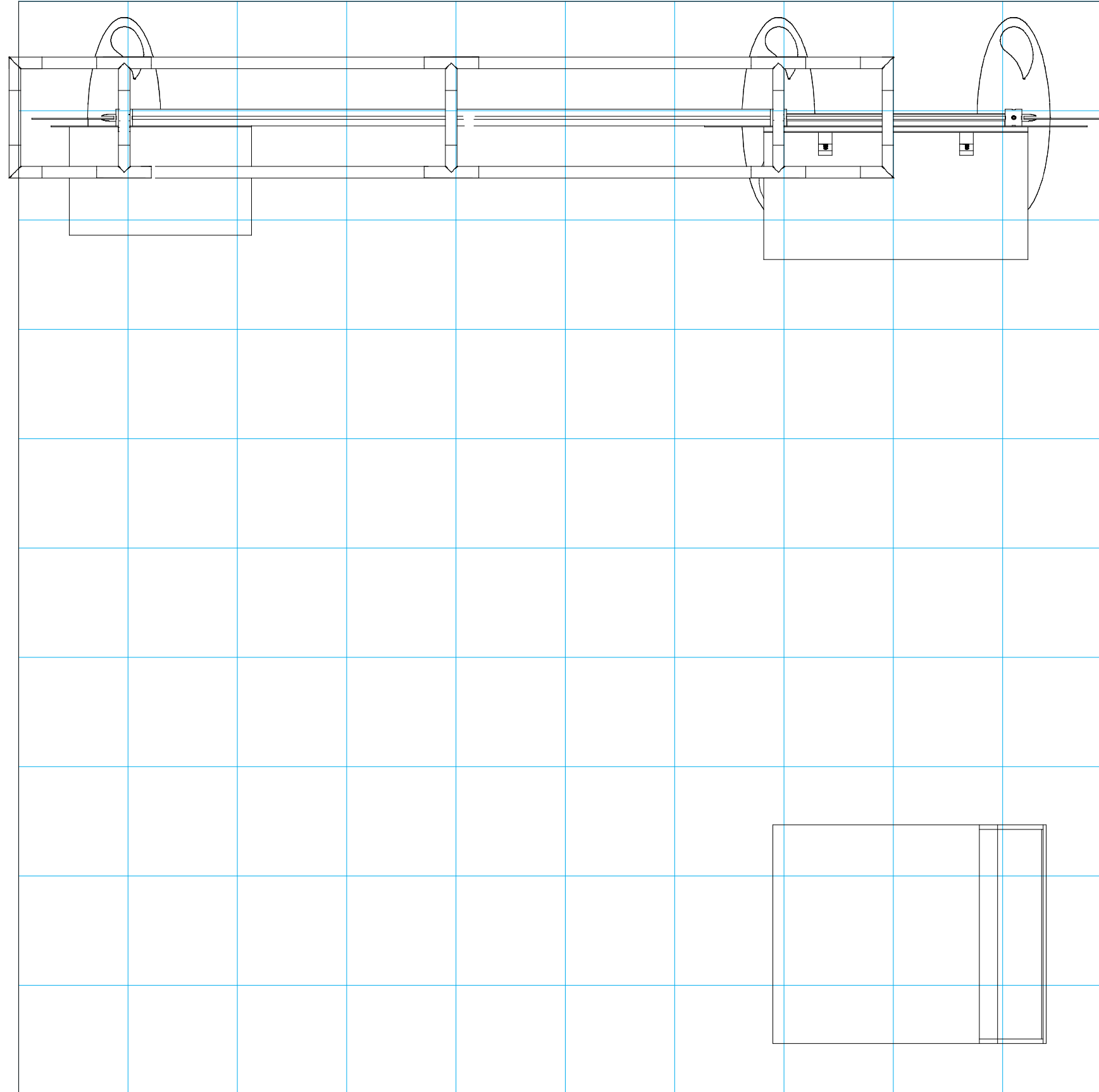

= 1 sq foot

General Setup Instructions

- Read entire setup instruction manual prior to unpacking parts and pieces.
- The setup instructions are created specifically for this configuration.
- Setup instructions are laid out sequentially in steps, including exploded views with detailed explanation for assembly.

Cleaning & Packing

- For Cleaning Metal, Plex, & Laminate Parts: Use a **MILD NON-ABRASIVE** cleanser and soft cloth/paper towel to clean all surfaces.
- Keep exhibit components away from heat and prolonged sun exposure. **Heat and UV exposure will warp and fade components.**
- Retain all provided Packing Materials. All provided packing materials are for ease of repacking & component protection.

Disassembly

- For loss prevention, tighten all set screws and locks during disassembly.

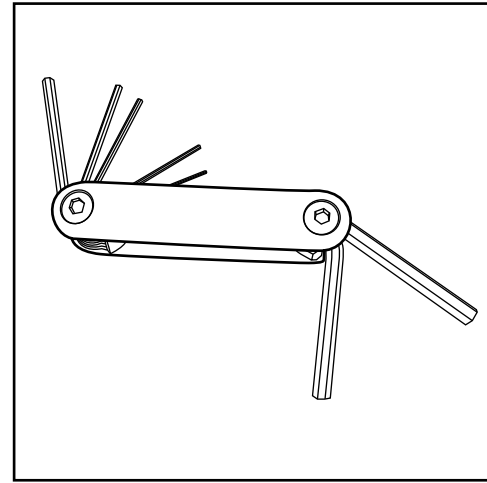

Hex Tool - Essential for Assembly

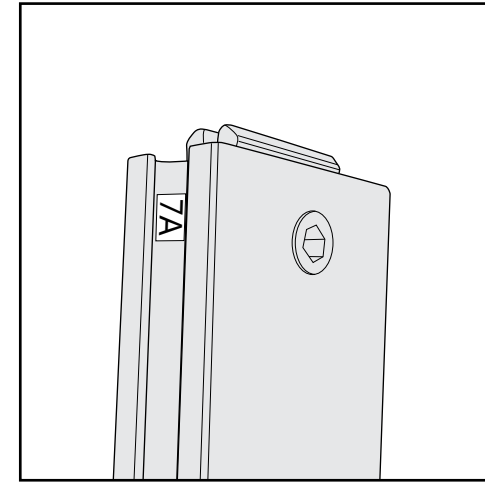

Part Identification - Numbering

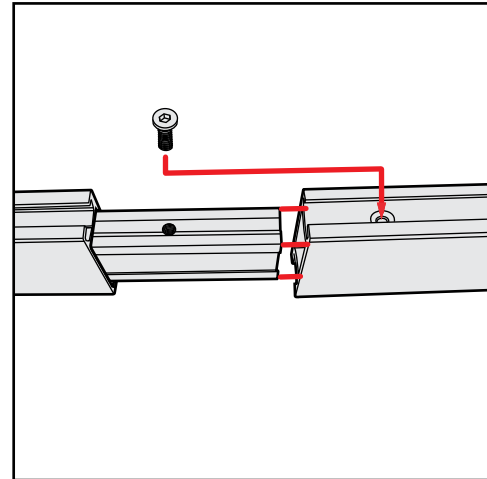

Spline Connection

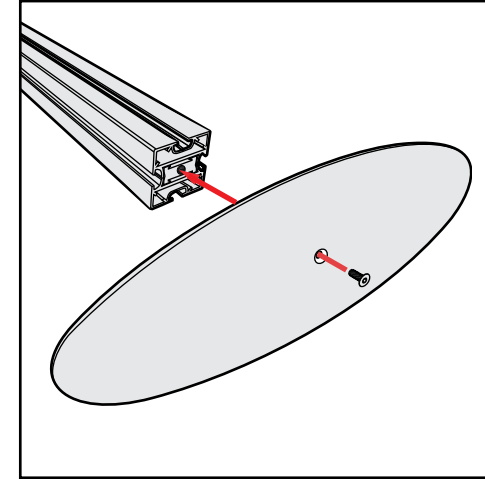

Base Plate & Extrusion Connection

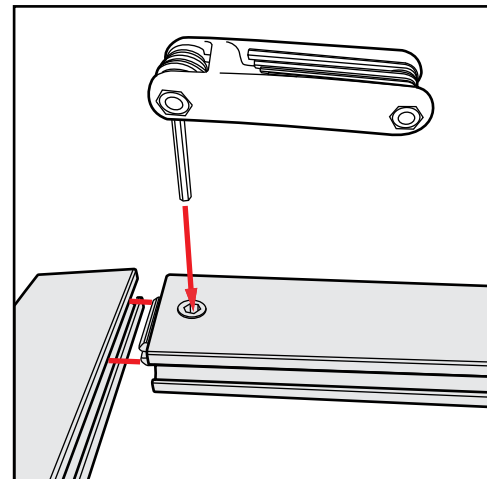

Extrusion & Lock Connection

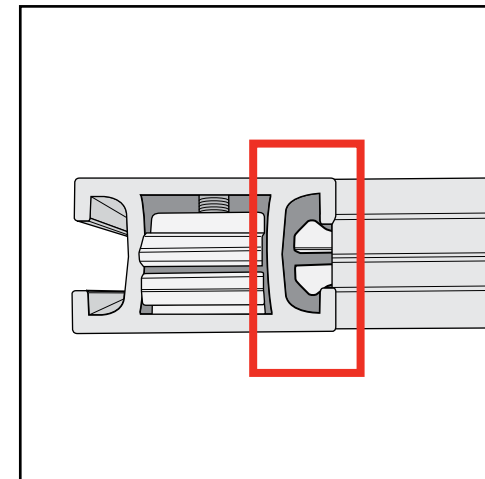

Engaged Lock



WARNING



DO NOT USE POWER TOOLS

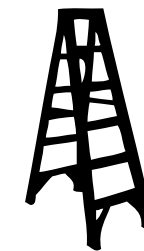

LADDERS OR LIFTS
MAY BE REQUIRED



ALL CONNECTIONS MUST
BE TIGHTLY SECURED

Item	Qty.	Description
1	3	Base Plate
2	1/1	86"h Vertical Extrusion
3	1/1	86"h Vertical Extrusion
4	1/1	86"h Vertical Extrusion
5	1/1	70"w Horizontal Extrusion
6	1/1	70"w Horizontal Extrusion
7/7A	1/1	24"w Horizontal Extrusion

- Steps:
- 1) Connect verticals to base plates with bolts.
 - 2) Connect lower and upper horizontals between verticals.
 - 3) Attach graphics to backwall where indicated.

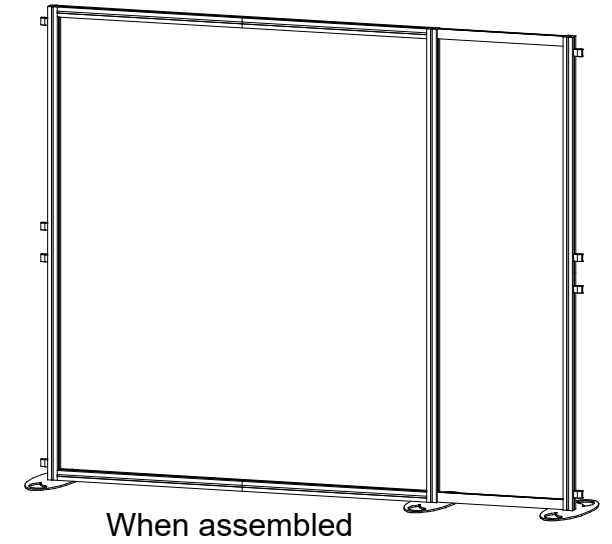
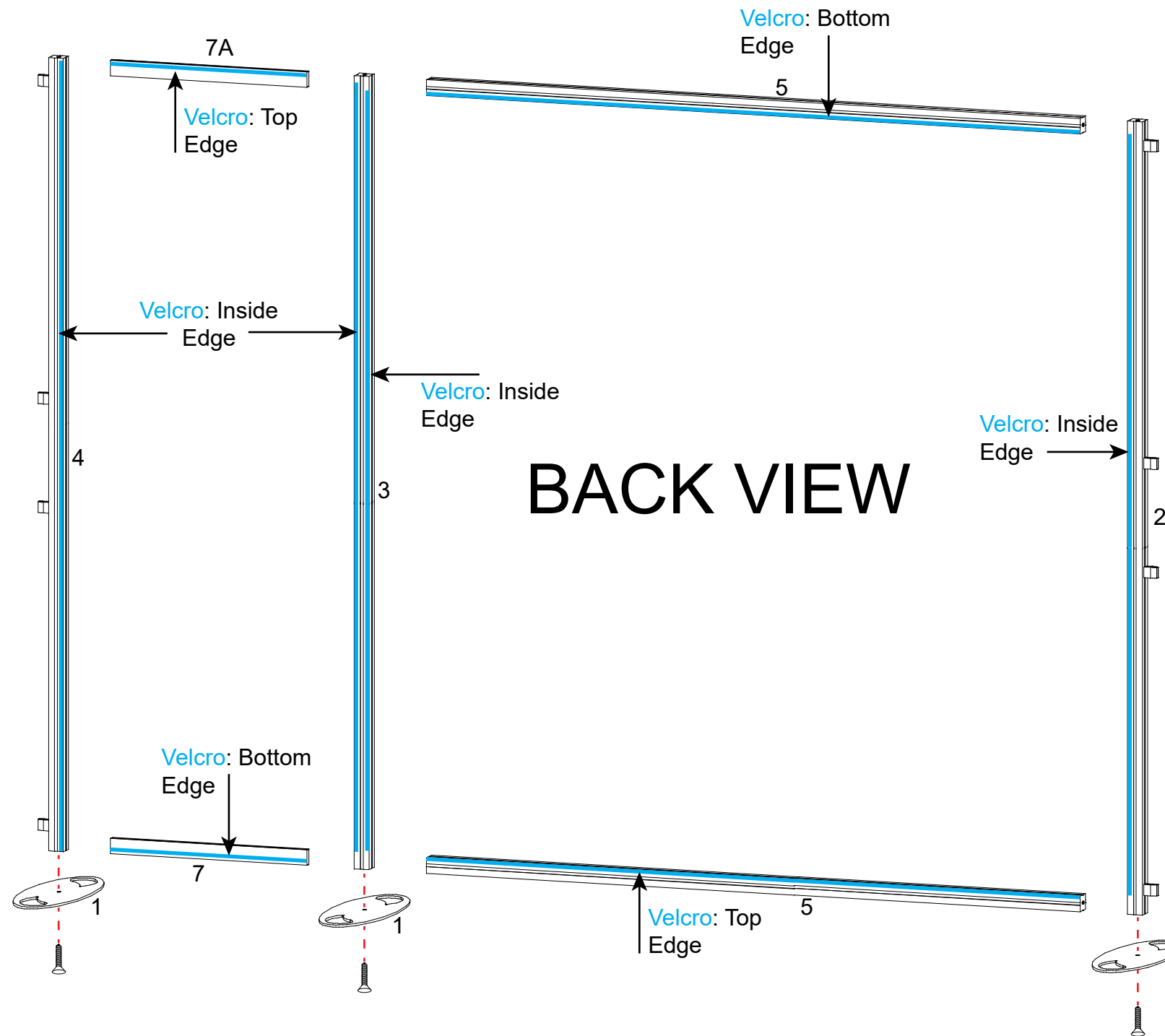

Item	Qty.	Description
8/8A	1/1	24.5"h Vertical Extrusion
9/9A	1/1	24"w Horizontal Extrusion
10/10A	1/1	12"w Horizontal Extrusion

- Steps:
- 1) Attach graphic with stand off caps as shown in detail.
 - 2) Connect horizontals [9] & [9A] between verticals [8] & [8A].
 - 3) Connect lower horizontals [10] between verticals.
 - 4) Attach infills between verticals on top of lower horizontal [10].
 - 5) Attach upper horizontal [10A].

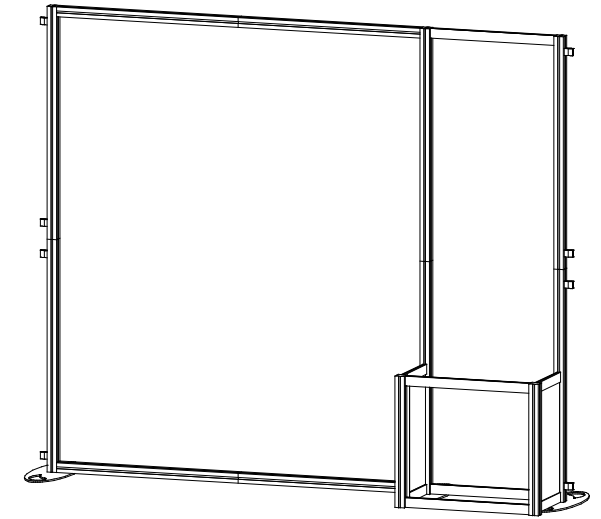

When assembled

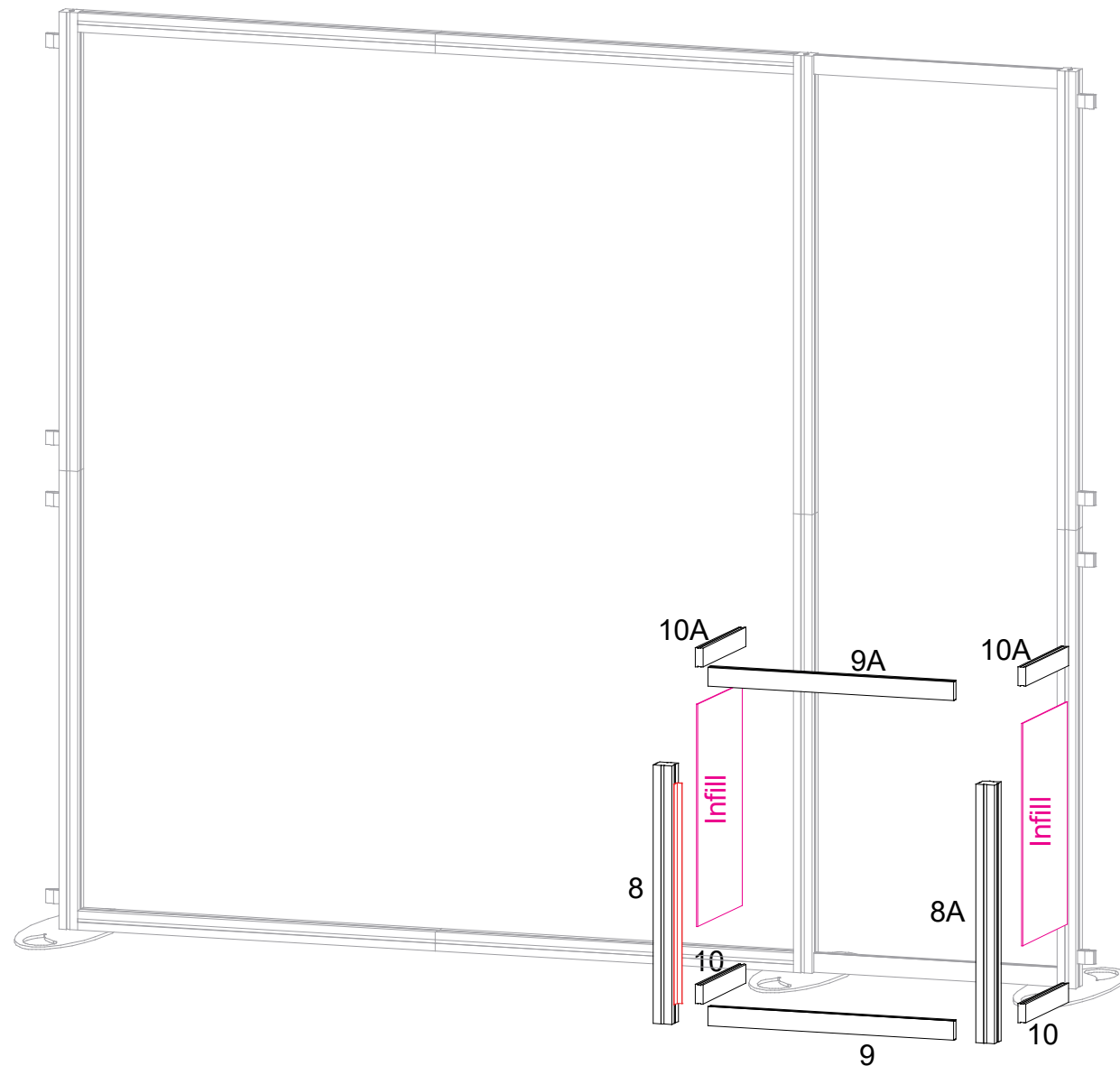

*** Counter Top Attachment**

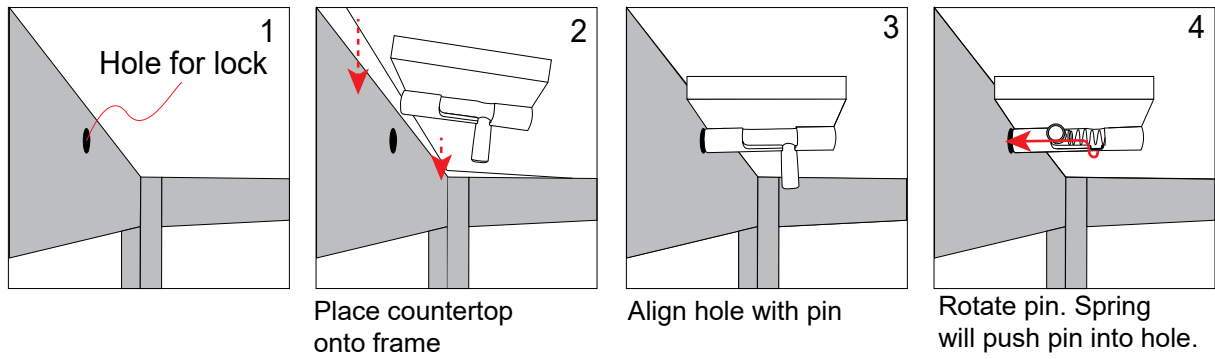

Steps:

- 1) Attach wings to backwall.
See **Clamp Attachment** detail.
- 2) Connect door to counter base.
See **Door Attachment** detail.
- 3) Place counter top on top of counter base.
See **Counter Top Attachment** detail.
- 4) Attach monitor mount to verticals [3] & [4].
See **Monitor Mount Attachment** detail.

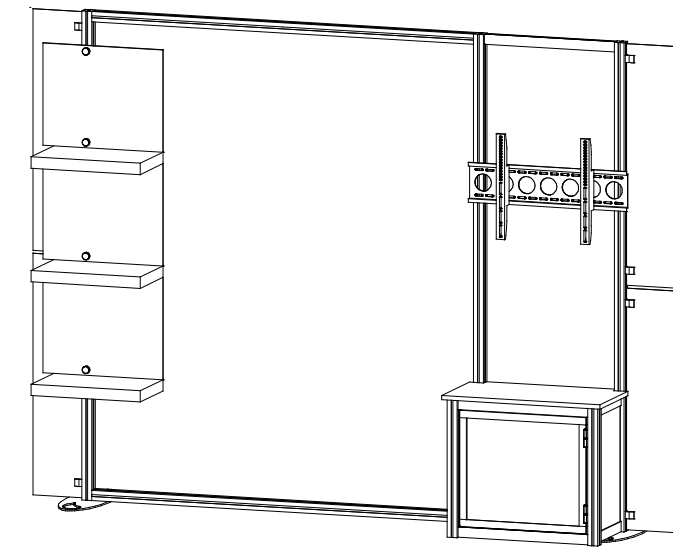

When assembled

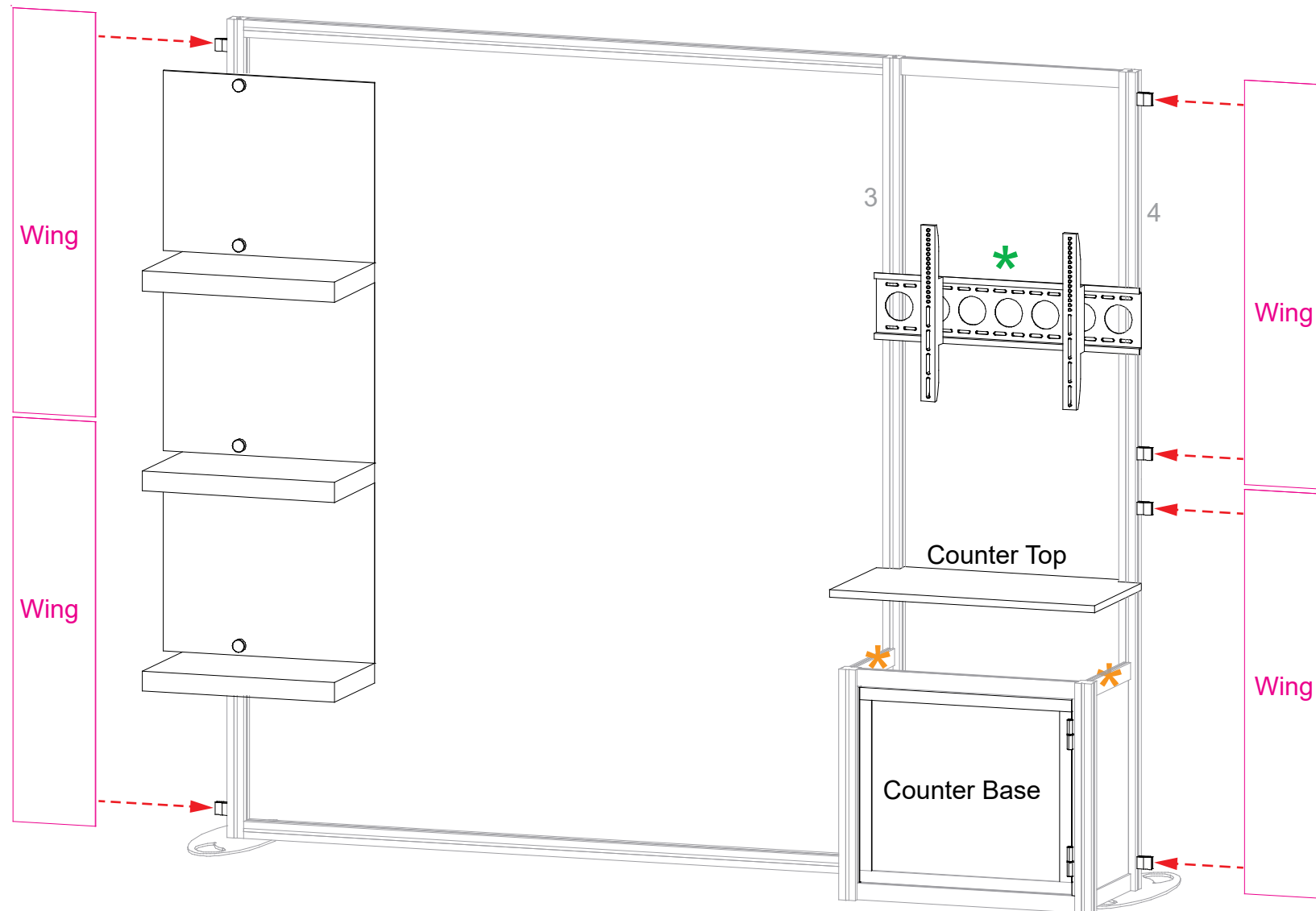

*** Door Connection**

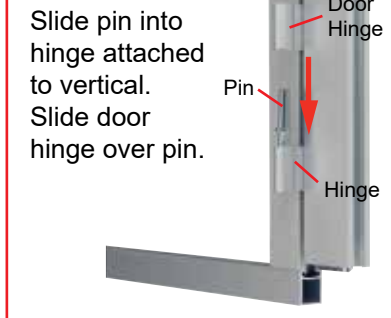

*** Monitor Mount Attachment**

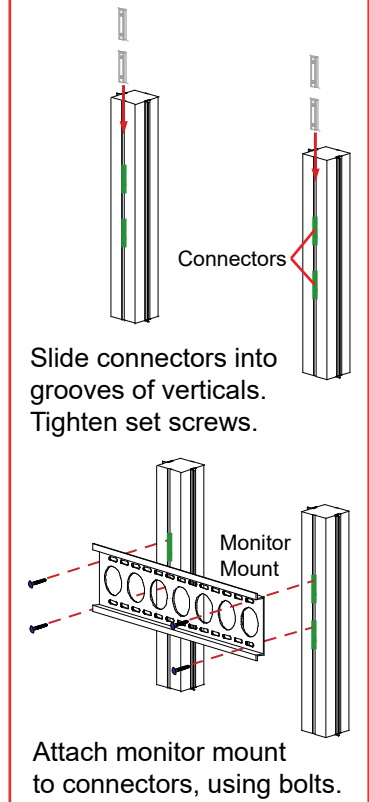

*** Clamp Attachment**

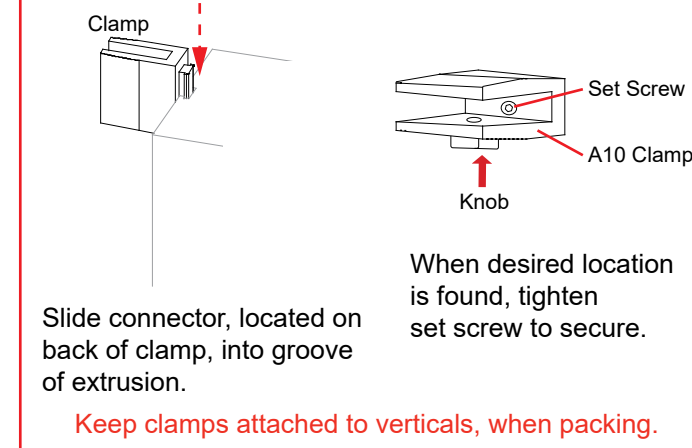

AERO

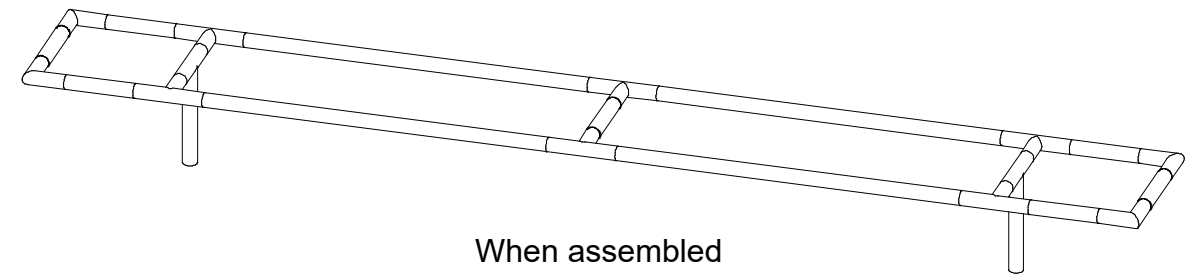

Using Your Setup Instructions

The Aero Setup Instructions are created specifically for your configuration. The instructions include an exploded view of the frame which is sequentially labeled. We encourage you to review the instructions before attempting to assemble your exhibit.

Connections are kept very simple; no tools required. Everything assembles with push-button connectors.

Cleaning and Packing Your Display

- 1) Use care when cleaning aluminum extrusion or acrylic inserts. Use only non-abrasive cleaners.
- 2) Retain all packing material. It will make re-packing much easier and will reduce the likelihood of shipping damage.

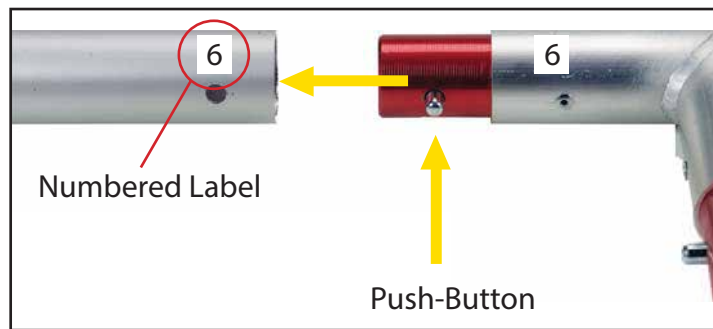

Connections are made by holding the button down and sliding the red tube into opposing tube until button locks into the hole of the opposing tube. To disassemble, push button and pull or twist extrusions apart.

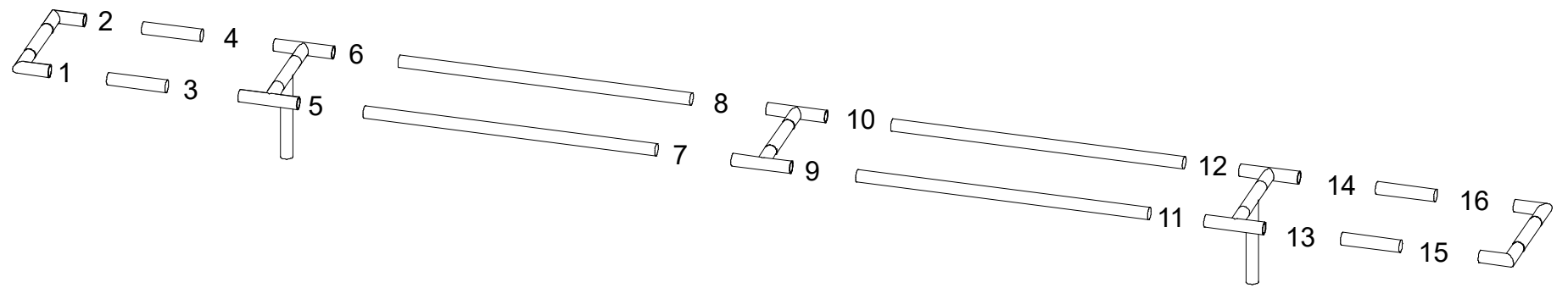
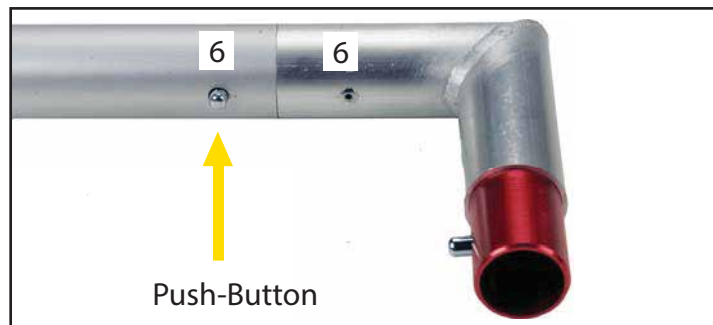

Steps:

- 1) Use canopy attachment to attach canopy to upper verticals.
- 2) Attach light as shown in detail.
- 3) Attach graphic to velcro where indicated.

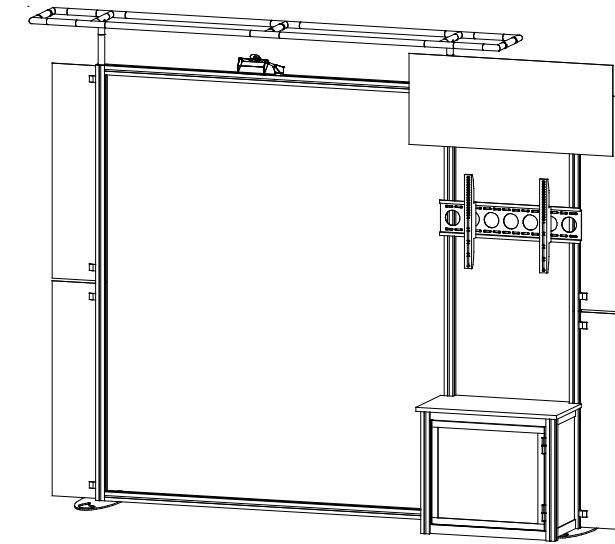
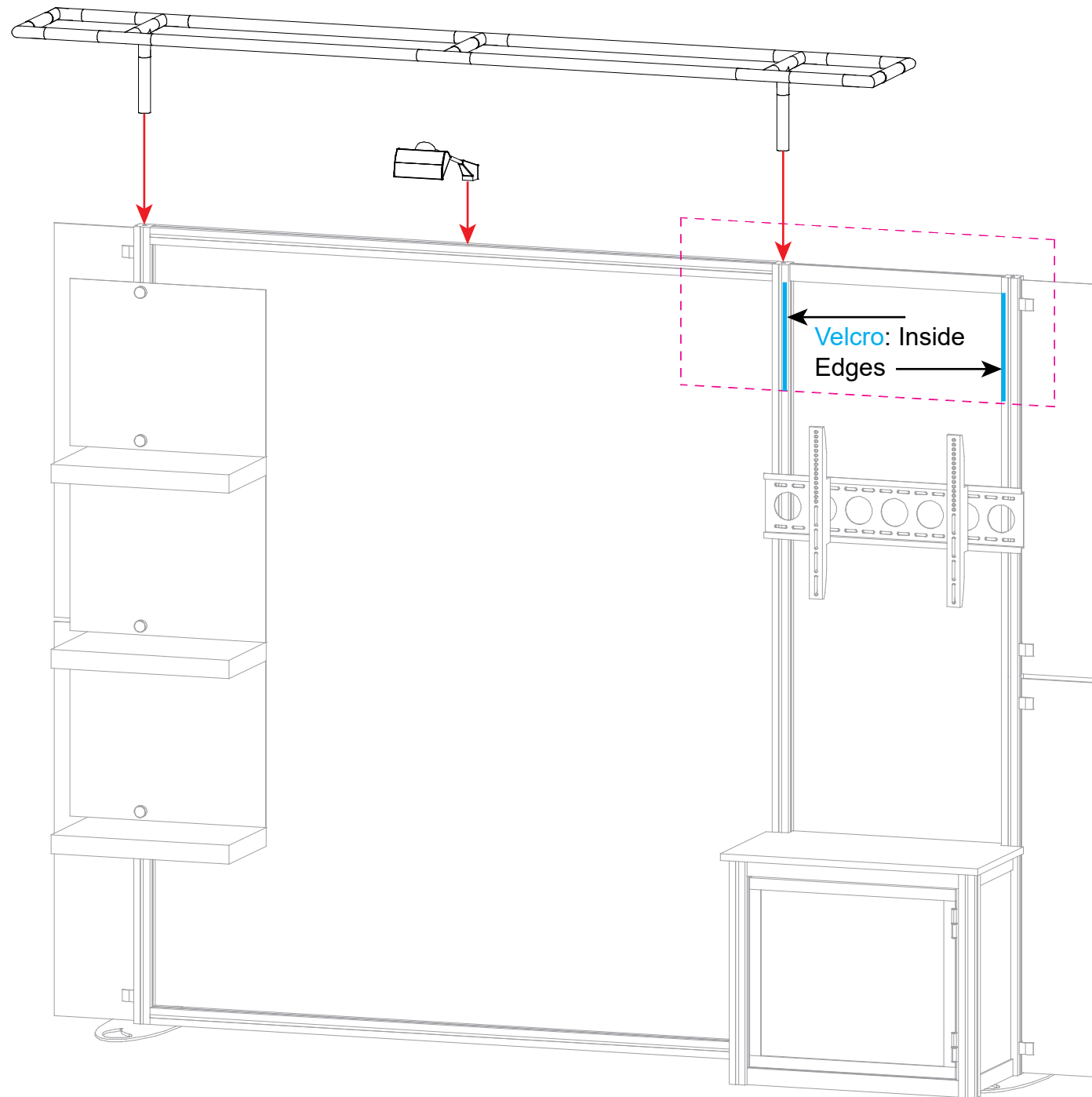

When assembled