

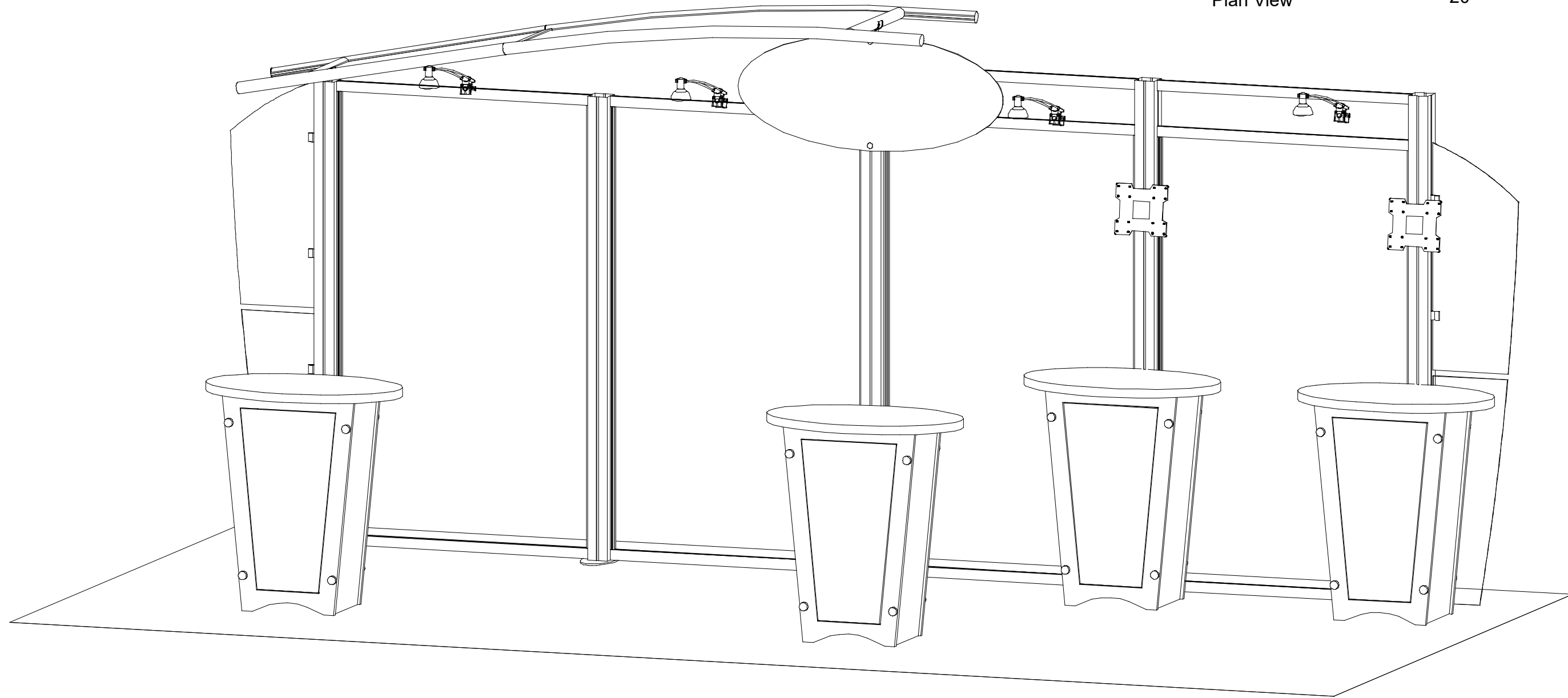

Plan View

20'

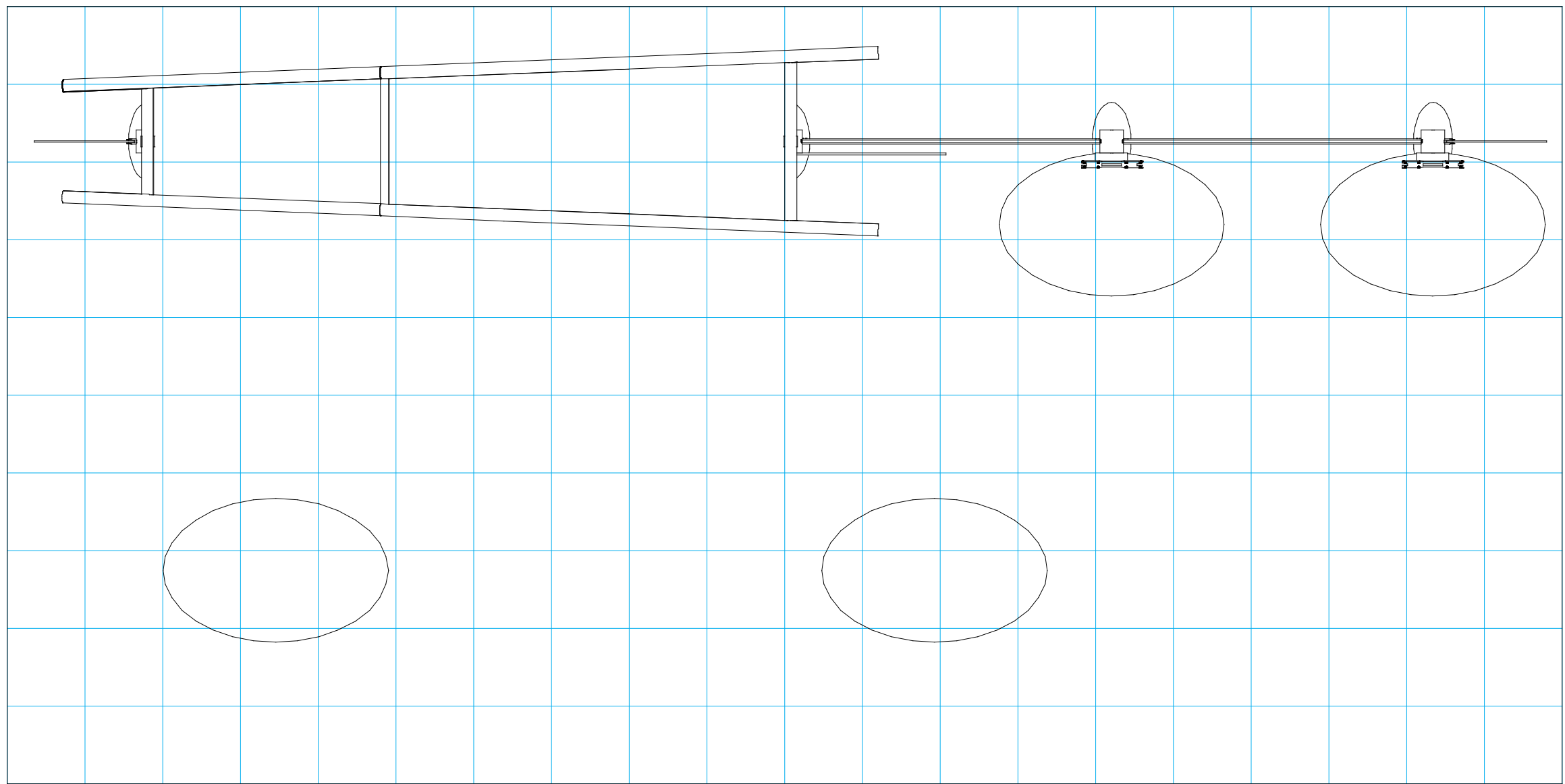

SETUP INSTRUCTIONS



 = 1 sq foot

General Setup Instructions

- Read entire setup instruction manual prior to unpacking parts and pieces.
- The setup instructions are created specifically for this configuration.
- Setup instructions are laid out sequentially in steps, including exploded views with detailed explanation for assembly.

Cleaning & Packing

- For Cleaning Metal, Plex, & Laminate Parts: Use a **MILD NON-ABRASIVE** cleanser and soft cloth/paper towel to clean all surfaces.
- Keep exhibit components away from heat and prolonged sun exposure.
Heat and UV exposure will warp and fade components.
- Retain all provided Packing Materials. All provided packing materials are for ease of repacking & component protection.

Disassembly

- For loss prevention, tighten all set screws and locks during disassembly.

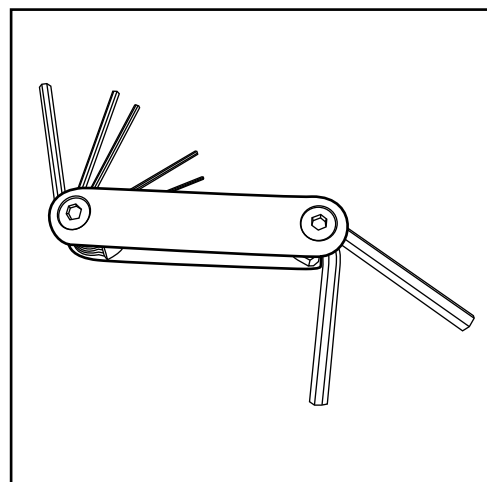

Hex Tool - Essential for Assembly

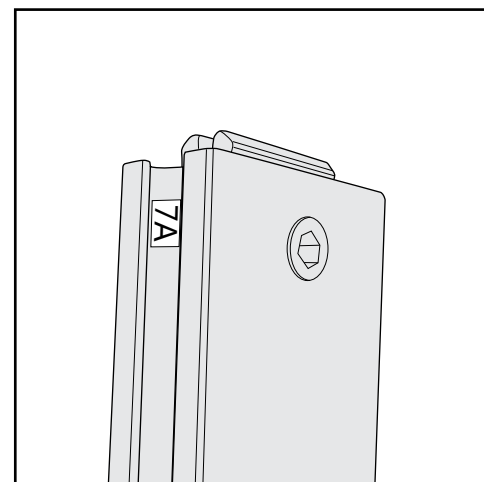

Part Identification - Numbering

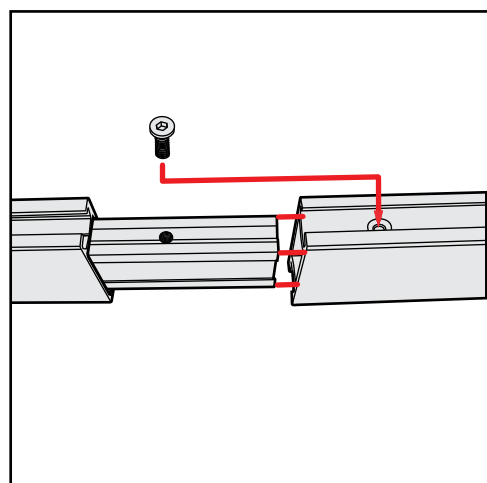

Spline Connection

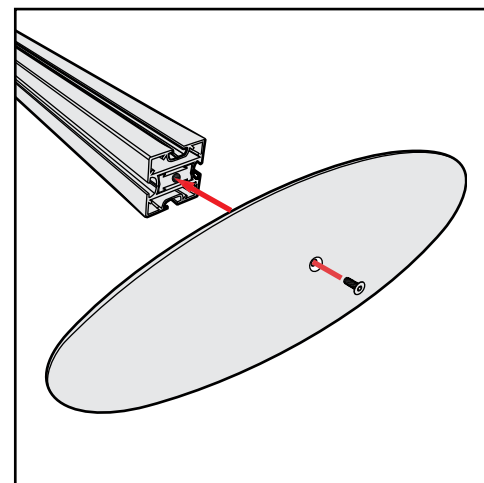

Base Plate & Extrusion Connection

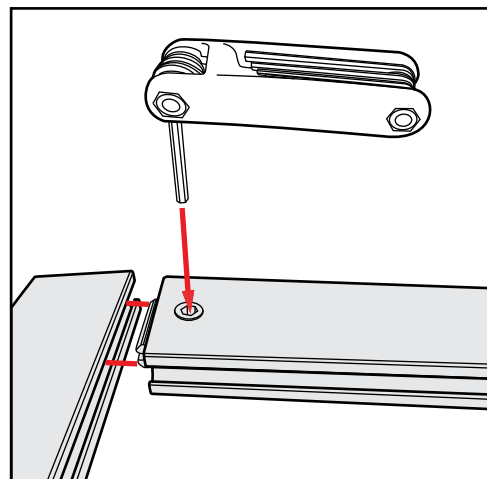

Extrusion & Lock Connection

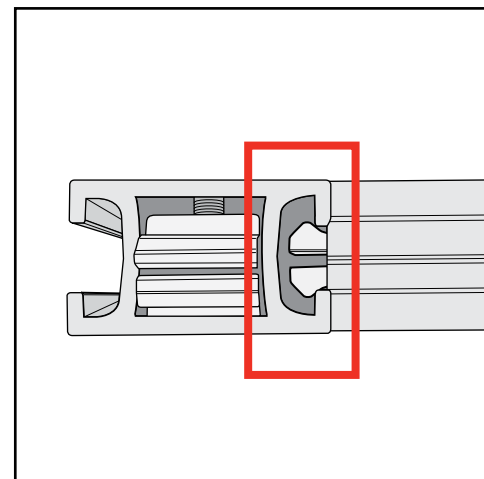

Engaged Lock



WARNING

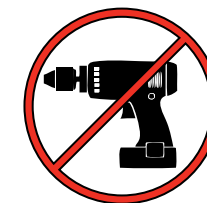

DO NOT USE POWER TOOLS



LADDERS OR LIFTS
MAY BE REQUIRED



ALL CONNECTIONS MUST
BE TIGHTLY SECURED

CRATE PACKING

Item	Qty.	Description
1	5	Oval Baseplate
2	1	80" Vertical Extrusion
3	1	80" Vertical Extrusion
4	1	80" Vertical Extrusion
5	1	80" Vertical Extrusion
6	1	80" Vertical Extrusion
7/7a	1/1	46" Horizontal Extrusion
8/8a	1/1	46" Horizontal Extrusion
9/9a/9b	1/1/1	46" Horizontal Extrusion
10/10a/10b	1/1/1	46" Horizontal Extrusion

Steps:

- 1) Attach Oval Baseplates to Vertical Extrusions [2, 3, 4, 5, 6]
- 2) Connect Horizontal Extrusions [7, 7a, 8, 8a, 9, 9a, 9b, 10, 10a, 10b] between Vertical Extrusions [2, 3, 4, 5, 6] as shown.
- 3) Connect Wings to Vertical Extrusions [2, 6] as shown (see Clamp Attachment Detail).
- 4) Attach lights to Horizontal Extrusions where desired.

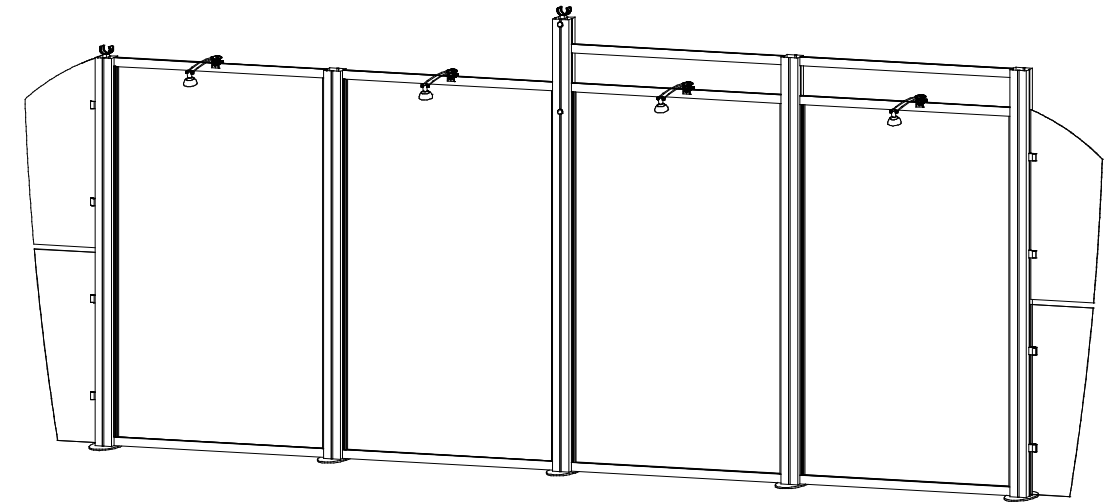
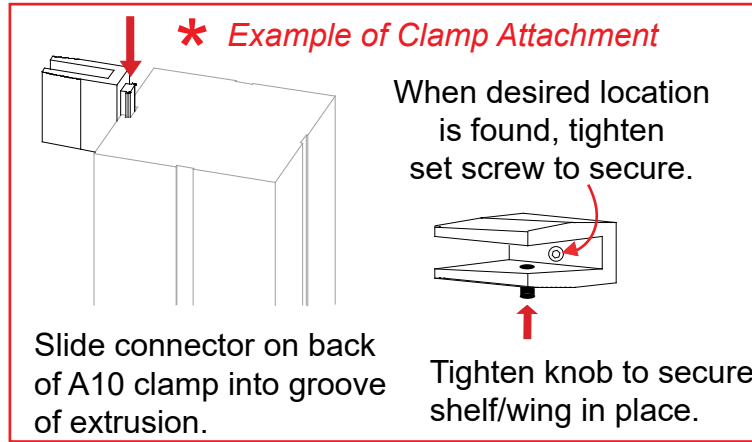

When assembled

Velcro indicated in **BLUE**

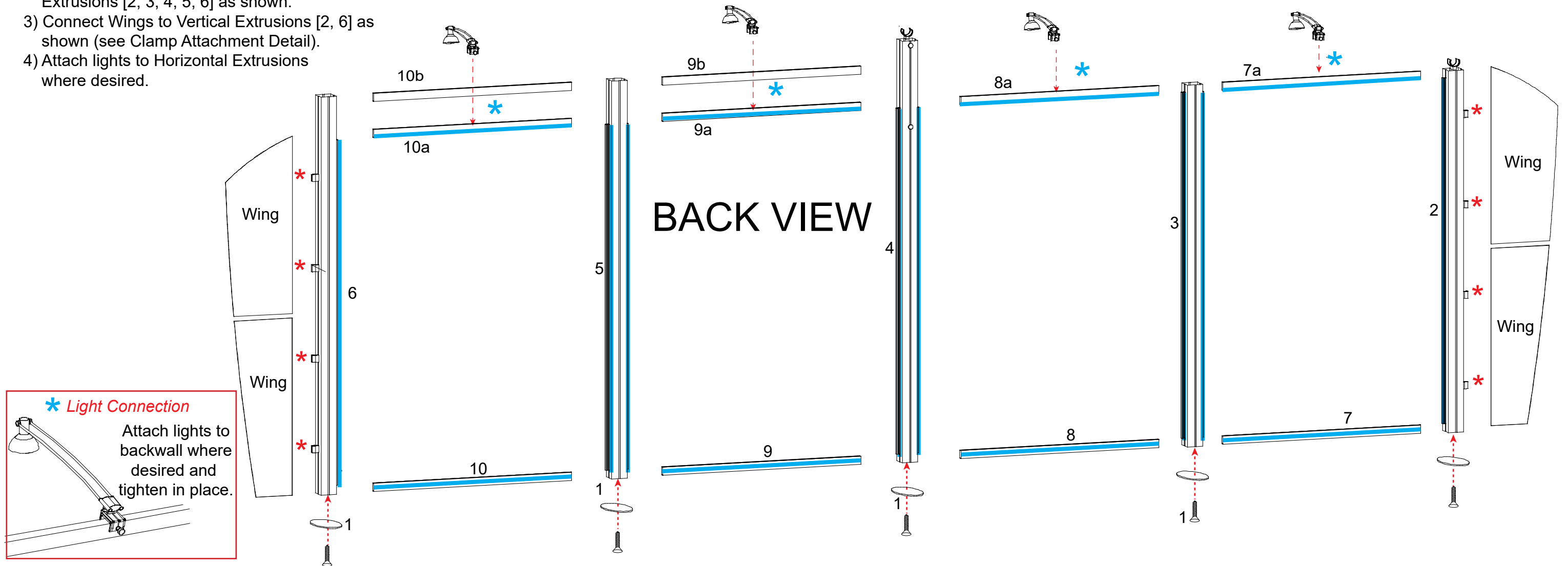

Item	Qty.	Description
11	1	16.4" Horizontal Extrusion
12	1	19.4" Horizontal Extrusion
13	1	24.5" Horizontal Extrusion
14/14a	1/1	50.0" Extrusion
15/15a	1/1	76.75" Curved Extrusion

- Steps:
- 1) Attach Extrusions [14, 14a] to ends of Extrusions [15, 15a] as indicated.
 - 2) Insert Infills between Extrusions [14-15 & 14a-15a]
 - 3) Connect Extrusions [11, 12, 13] between Extrusions [14-15 & 14a-15a].
 - 4) Attach Header to assembled frame
 - 5) Connect Oval Graphic to Assembled frame (see Detail).

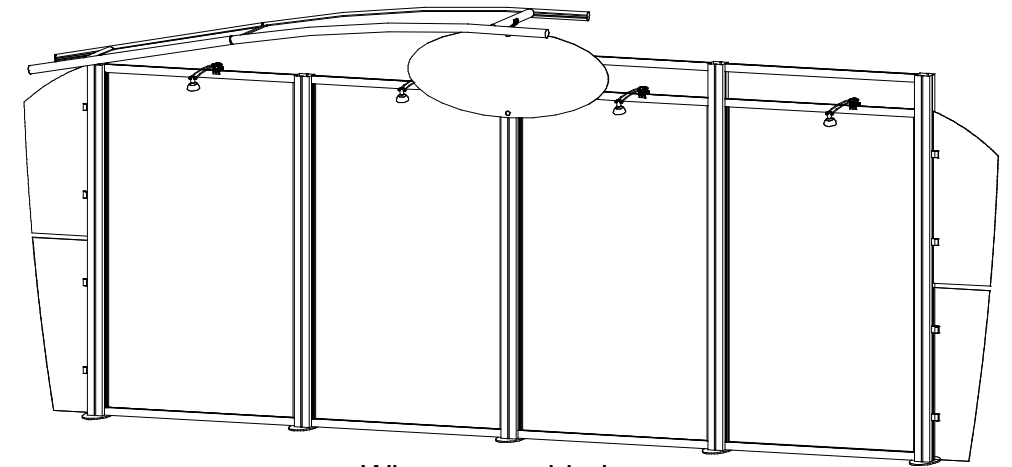

When assembled

Header Attachment Detail

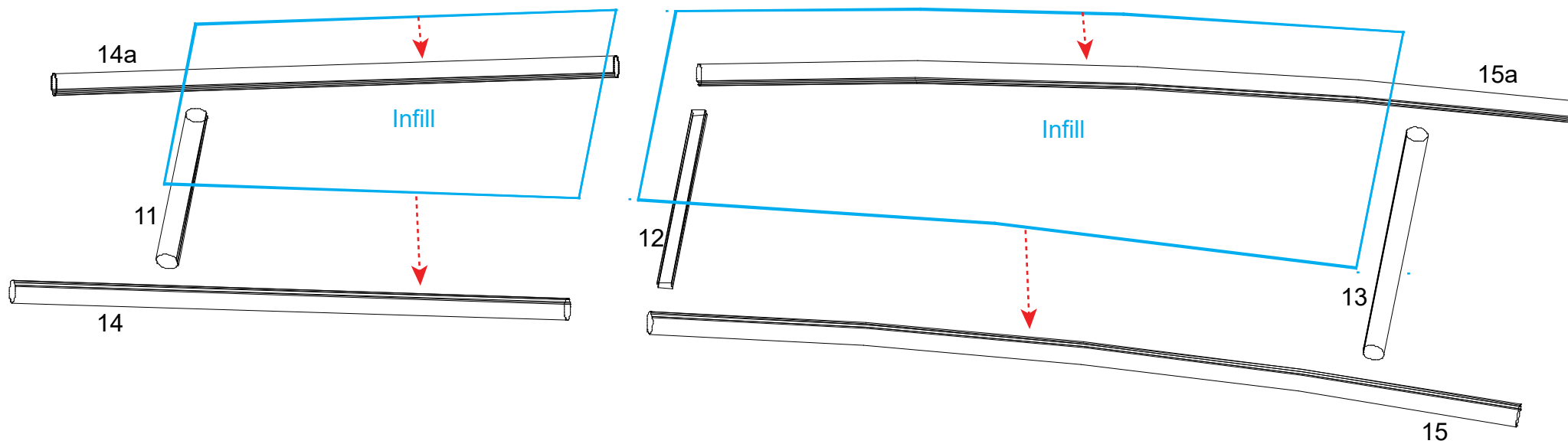
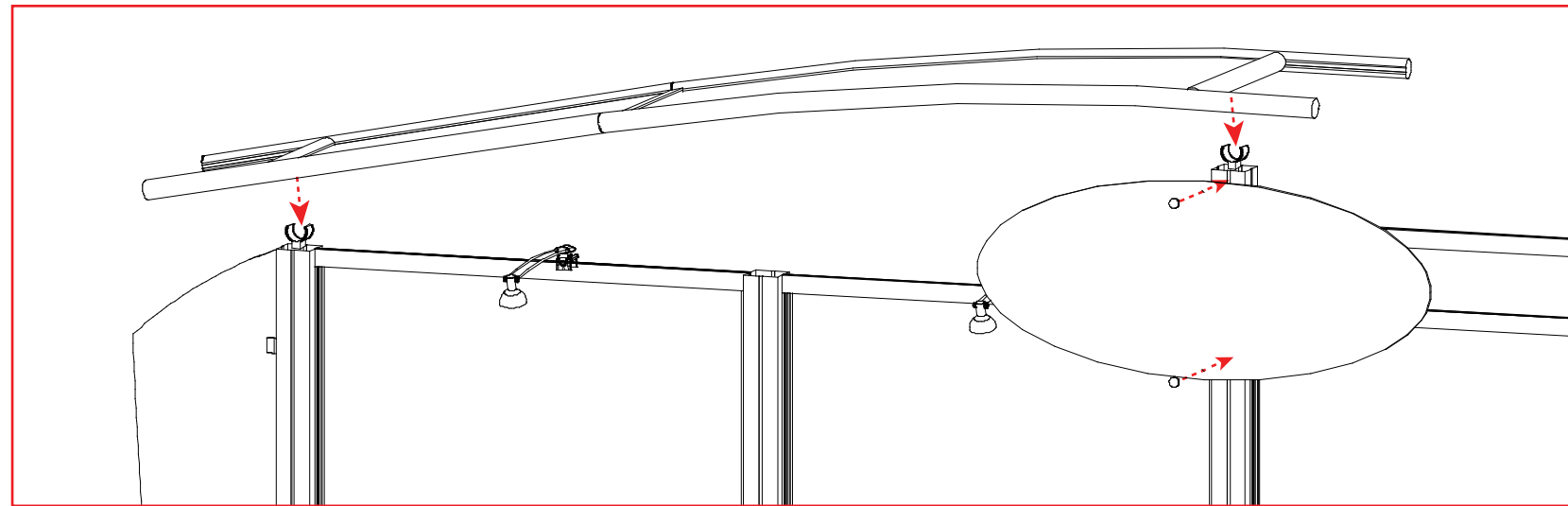

Graphic Attachment

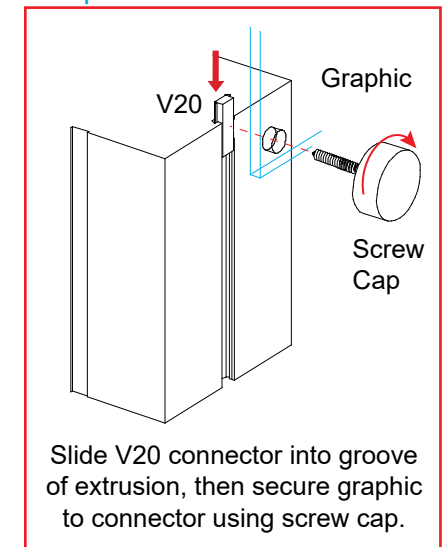

Slide V20 connector into groove of extrusion, then secure graphic to connector using screw cap.

Steps

- 1) Use standoff screws to secure the front panel with door and back panel of the pedestal to the side panels.
- 2) After assembling front, back, and side panels, slide floor into the bottom of the pedestal. The floor will sit on pins on the inside of the side panels.
- 3) After floor is in place, use velcro attachments to install shelf

QTY - 4

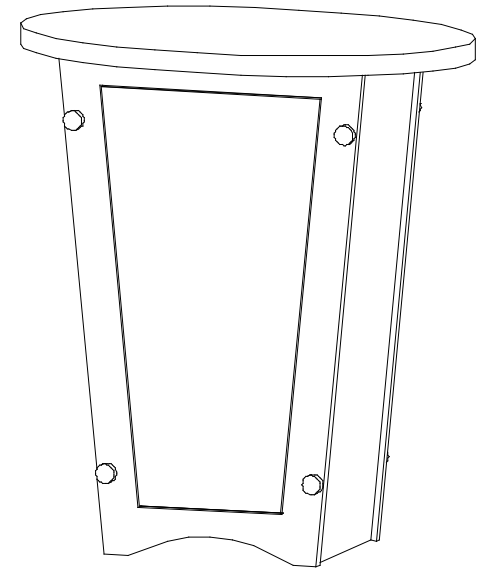
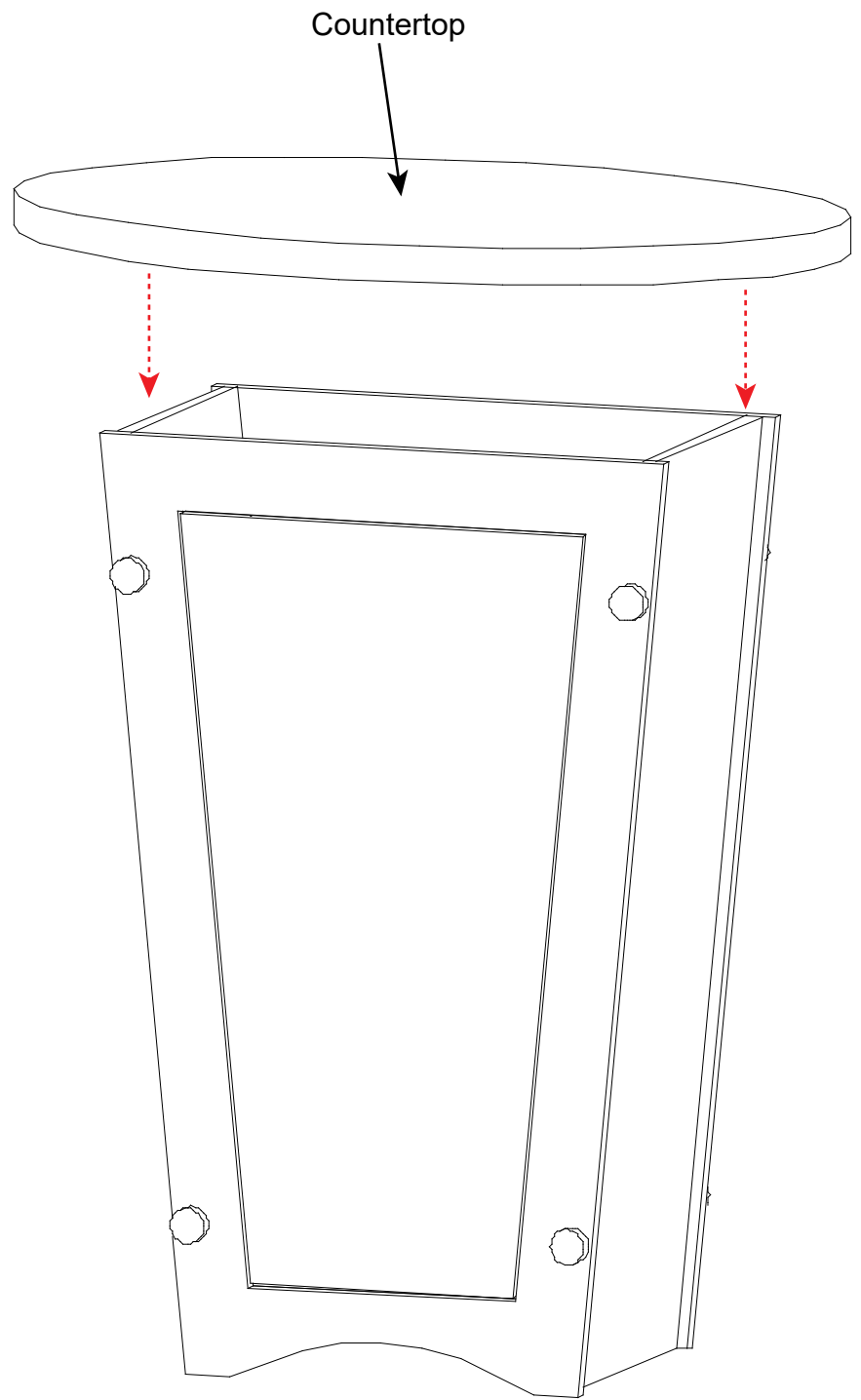
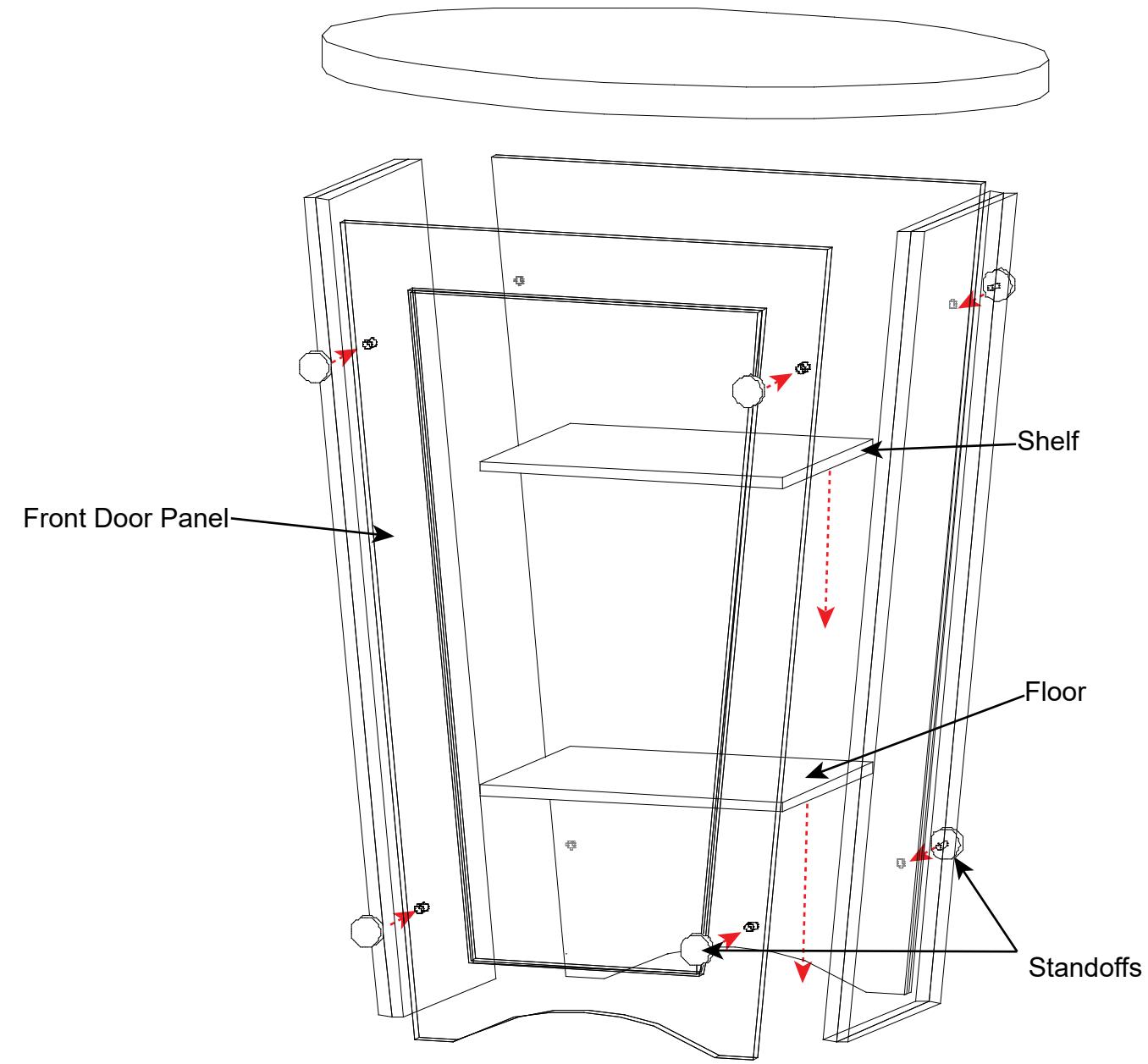

When assembled