

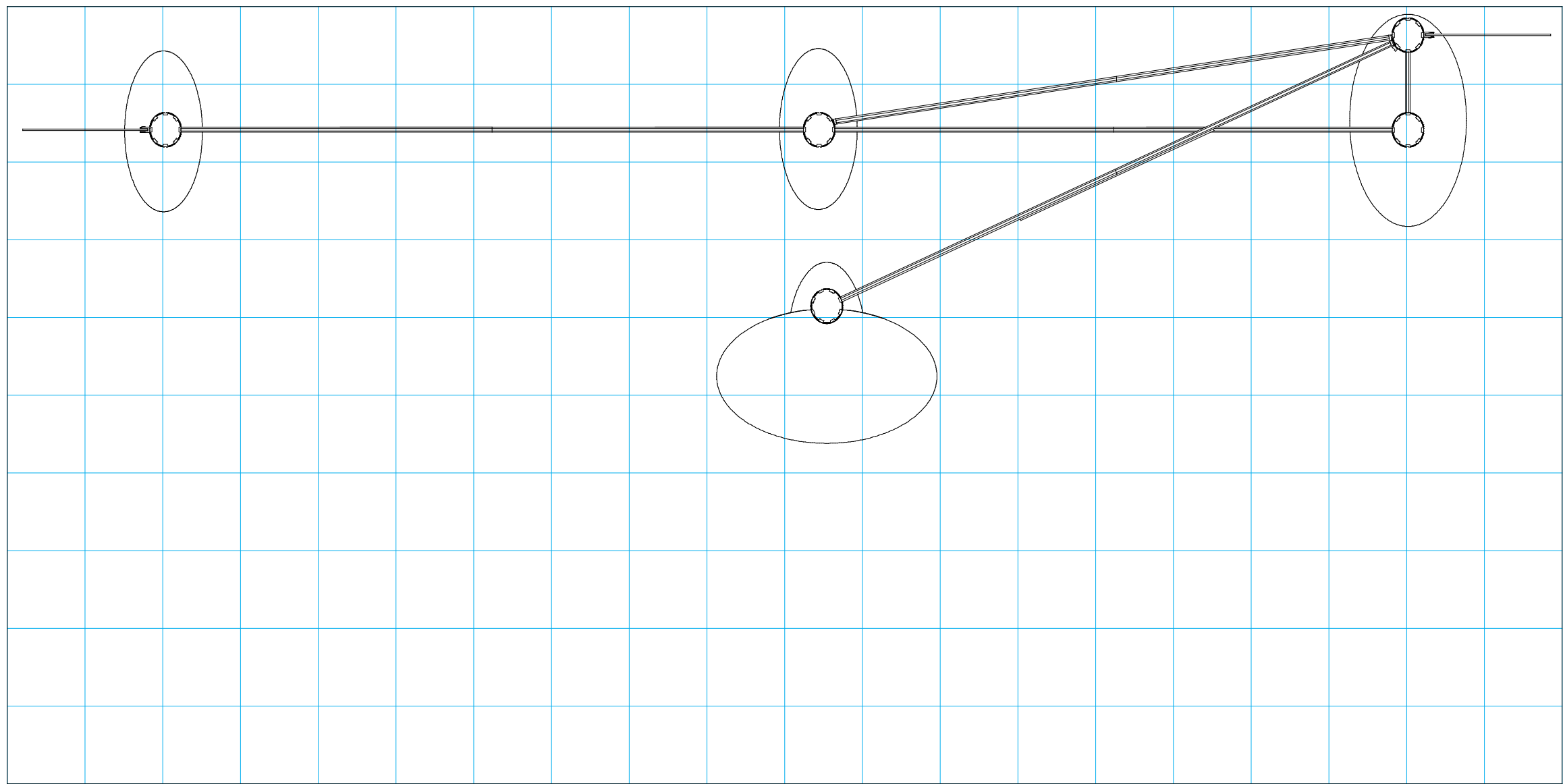

SETUP INSTRUCTIONS



 = 1 sq foot

General Setup Instructions

- Read entire setup instruction manual prior to unpacking parts and pieces.
- The setup instructions are created specifically for this configuration.
- Setup instructions are laid out sequentially in steps, including exploded views with detailed explanation for assembly.

Cleaning & Packing

- For Cleaning Metal, Plex, & Laminate Parts: Use a **MILD NON-ABRASIVE** cleanser and soft cloth/paper towel to clean all surfaces.
- Keep exhibit components away from heat and prolonged sun exposure. **Heat and UV exposure will warp and fade components.**
- Retain all provided Packing Materials. All provided packing materials are for ease of repacking & component protection.

Disassembly

- For loss prevention, tighten all set screws and locks during disassembly.

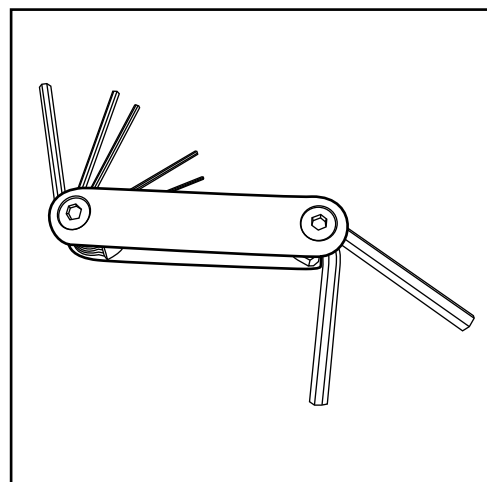

Hex Tool - Essential for Assembly

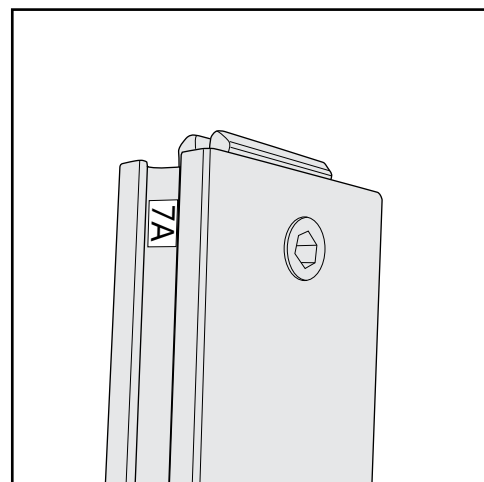

Part Identification - Numbering

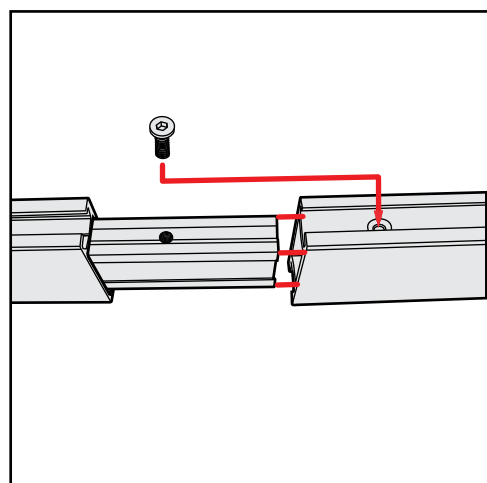

Spline Connection

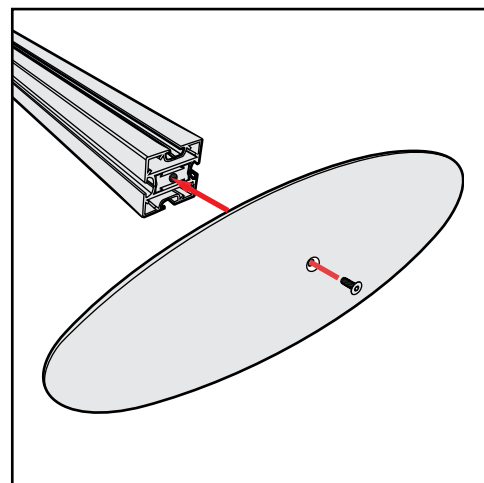

Base Plate & Extrusion Connection

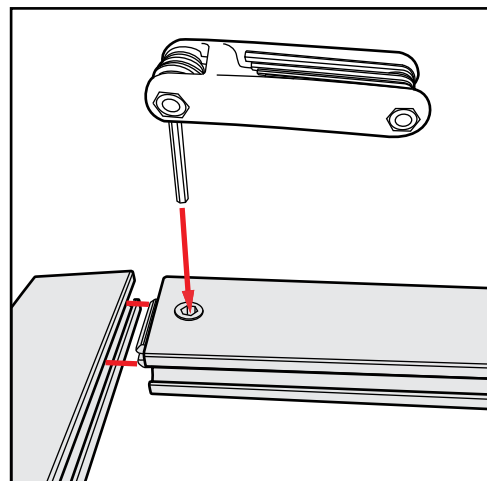

Extrusion & Lock Connection

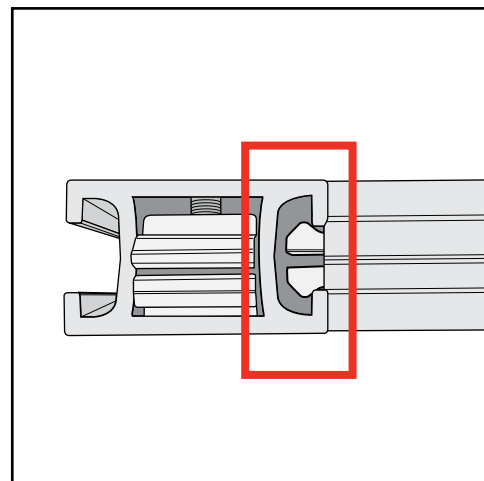

Engaged Lock



WARNING

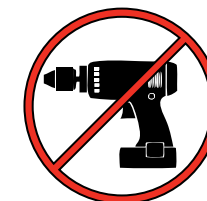

DO NOT USE POWER TOOLS



LADDERS OR LIFTS
MAY BE REQUIRED



ALL CONNECTIONS MUST
BE TIGHTLY SECURED

CRATE PACKING

Item	Qty.	Description
1/1a/1b	1/1/1	Base Plate
2	1	96"h Vertical Extrusion
3	1	79.7982"h Vertical Extrusion
4	1	96"h Vertical Extrusion
5	1	82.72"h Vertical Extrusion
6	1	8.037"w Horizontal Extrusion
7	1	98.477"w Horizontal Extrusion
8	1	86.16"w Horizontal Extrusion
9	1	86.02"w Horizontal Extrusion
10	1	88.843"w Horizontal Extrusion
11	1	8.3366"w Horizontal Extrusion
12	2	8.039"w Horizontal Extrusion

- Steps:**
- 1) Attach vertical extrusions [2, 3, 4 and 5] to base plates [1, 1a and 1b], see detail D on general info. page.
 - 2) Attach horizontal assemblies between vertical extrusions.
 - 3) Apply graphics to assembled backwall as shown.

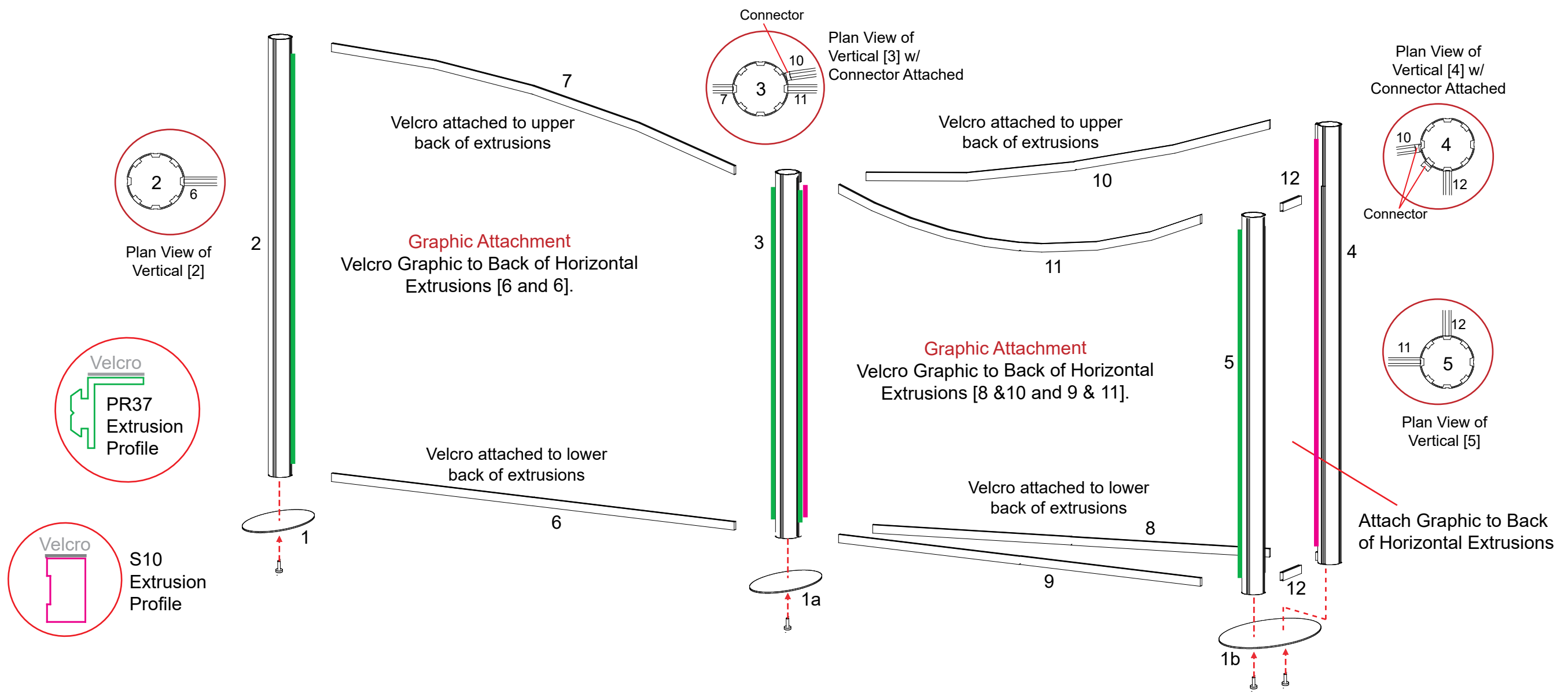
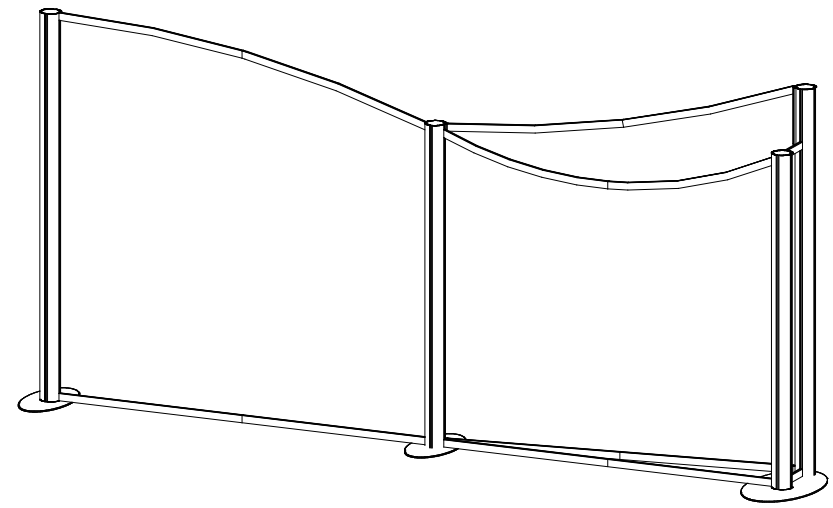

Item	Qty.	Description
1c	1	Base Plate
13a	1	Support Leg Left
13b	1	Support Leg Right
14	1	Shelf Support
15	1	96"h Vertical Extrusion
16a/16b	1/1	46.25"w Horizontal Extrusion
17a/17b	1/1	46.25"w Horizontal Extrusion

- Steps:
- 1) Attach vertical extrusion [15] and support legs [13a and 13b] to base plate [1c].
 - 2) Attach shelf support [14] between support legs [13a and 13b], then set shelf atop support with notched side fitting to vertical extrusion and secure with thumbscrews to vertical extrusion [15].
 - 3) Connect horizontal extrusions together [16a to 16b and 17a to 17b].
 - 4) Attach horizontal assemblies between vertical extrusions [4 and 15], placing insert as shown.
 - 5) Attach wings to vertical extrusions [2 and 4], see wing attachment detail.

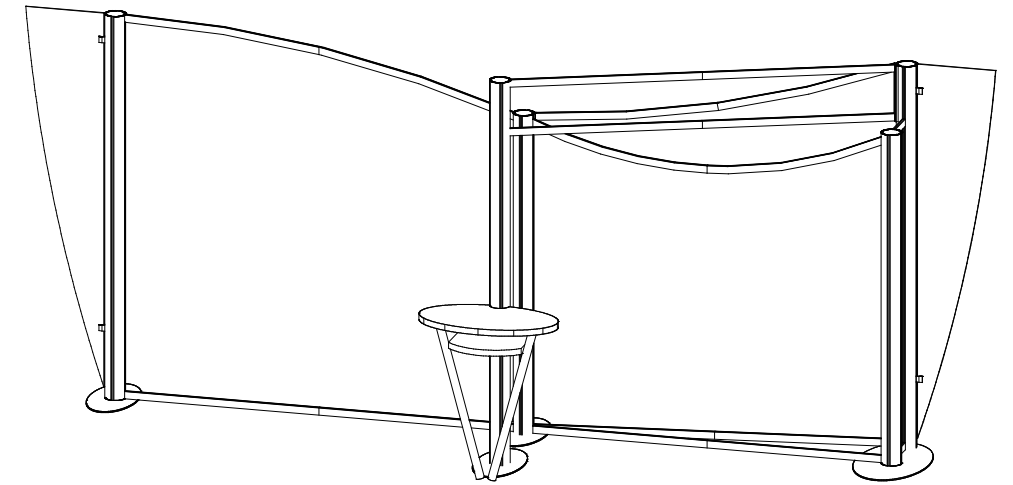

Wing Attachment
Slide A10 Clamp into groove of square extrusion.



When desired location is found, tighten set screw to secure.



Tighten black plastic set screw to secure Wing in place.