

Plan View

SETUP INSTRUCTIONS

General Setup Instructions

- Read entire setup instruction manual prior to unpacking parts and pieces.
- The setup instructions are created specifically for this configuration.
- Setup instructions are laid out sequentially in steps, including exploded views with detailed explanation for assembly.

Cleaning & Packing

- For Cleaning Metal, Plex, & Laminate Parts: Use a **MILD NON-ABRASIVE** cleanser and soft cloth/paper towel to clean all surfaces.
- Keep exhibit components away from heat and prolonged sun exposure. **Heat and UV exposure will warp and fade components.**
- Retain all provided Packing Materials. All provided packing materials are for ease of repacking & component protection.

Disassembly

- For loss prevention, tighten all set screws and locks during disassembly.

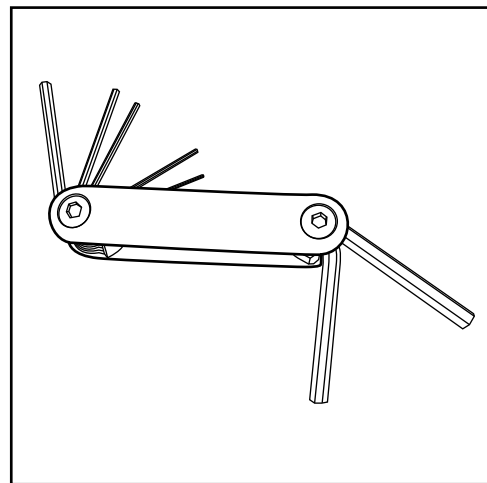

Hex Tool - Essential for Assembly

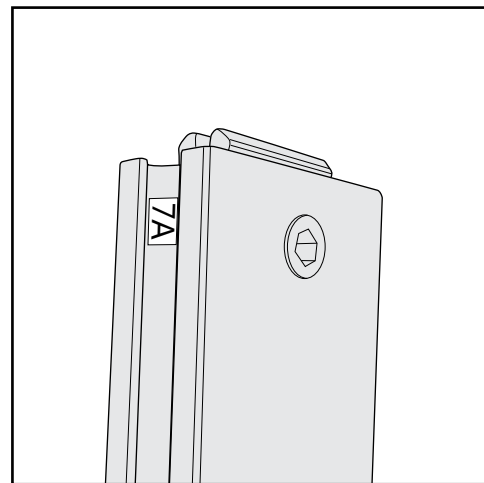

Part Identification - Numbering

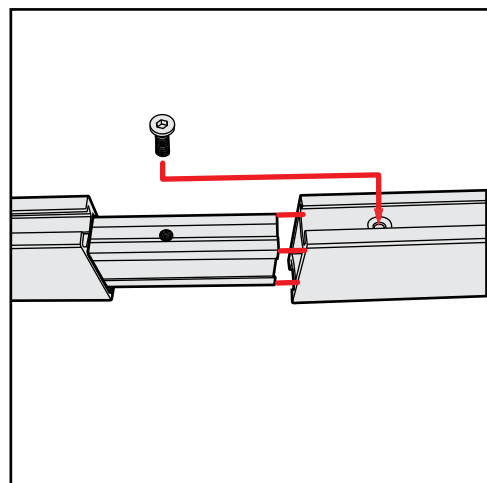

Spline Connection

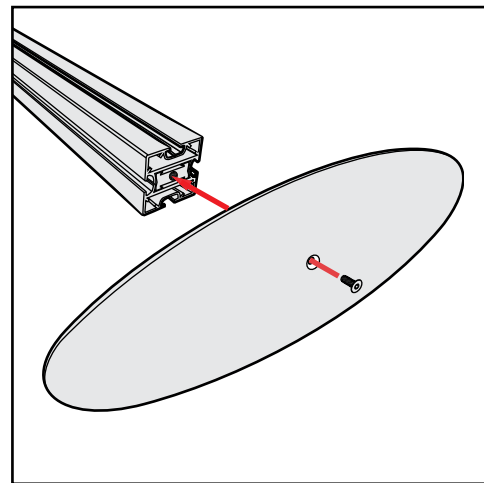

Base Plate & Extrusion Connection

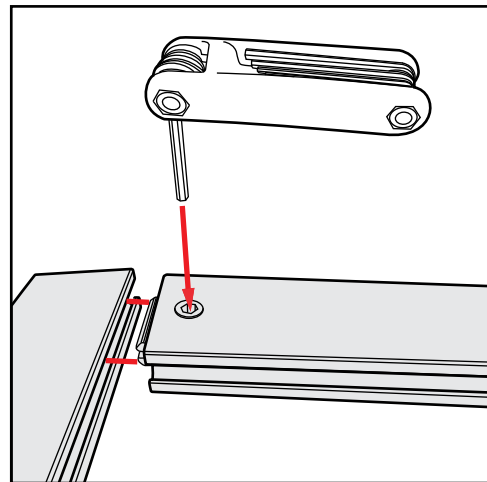

Extrusion & Lock Connection

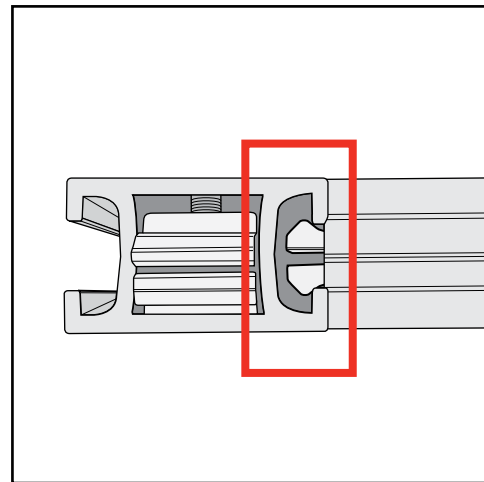

Engaged Lock



WARNING



DO NOT USE POWER TOOLS



LADDERS OR LIFTS
MAY BE REQUIRED



ALL CONNECTIONS MUST
BE TIGHTLY SECURED

Top View of Each Level

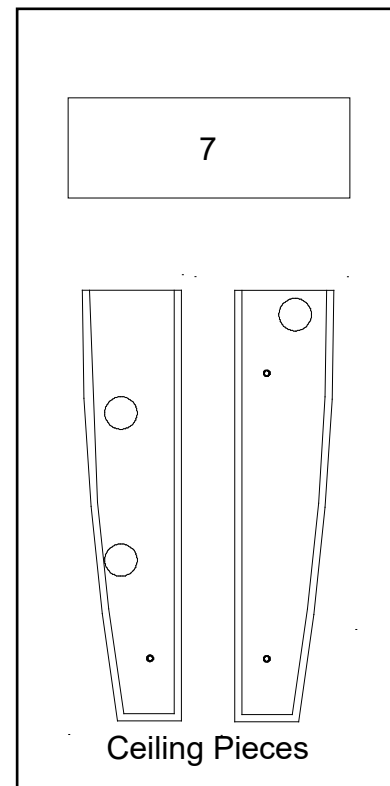

Level 1 (Bottom Level)

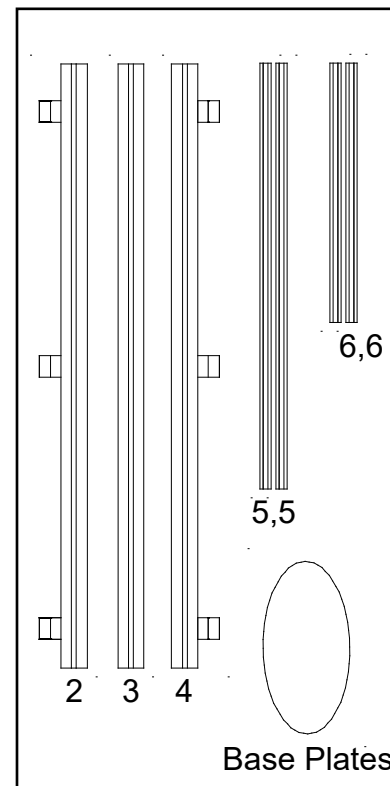

Level 2

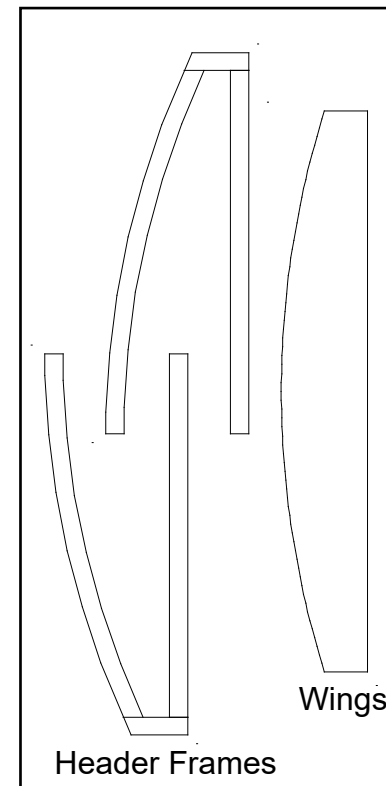

Level 3

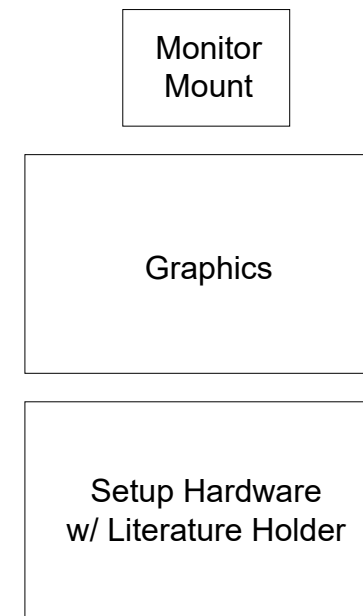

Item	Qty.	Description
1	3	Base Plate
2	1	42" S44 Vertical Extrusion
3	1	42" S44 Vertical Extrusion
4	1	42" S44 Vertical Extrusion
5	2	18" Z45 Horizontal Extrusion
6	2	29.5" Z45 Horizontal Extrusion
7	1	18" Z45 Horizontal Extrusion

- Steps:
- 1) Attach base plates to extrusions [2] [3] and [4] using bolts.
 - 2) Attach extrusions [6] and [7] between extrusions [2] and [3].
 - 3) Attach extrusions [5] between extrusions [3] and [4].
 - 4) Connect graphics to Velcro on back of assembled backwall.

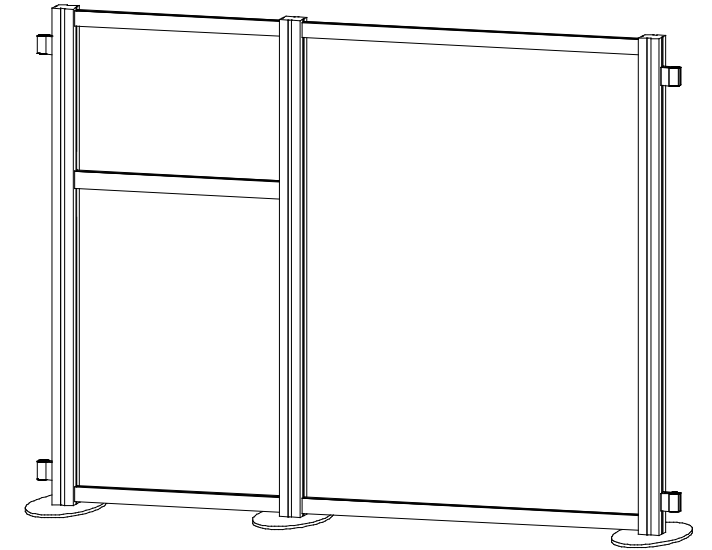

Completed Assembly

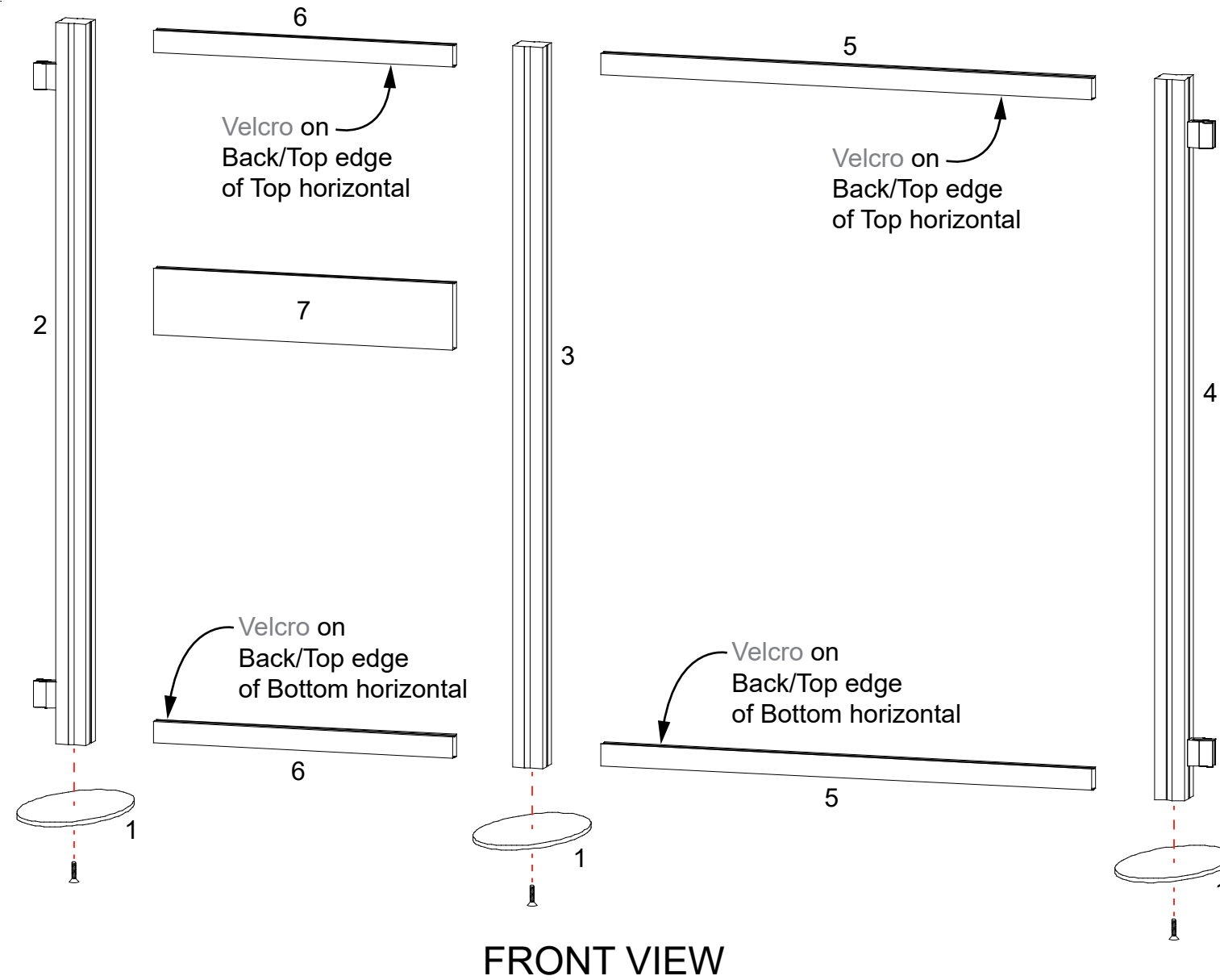

Item	Qty.	Description
8,8A	1,1	34" Z31 Horizontal Extrusion
9,9A	1,1	26.017" Z31 Curved Horizontal
10,10A	1,1	4.5" Z31 Vertical Extrusion

- Steps:
- 1) Connect ceiling pieces together.
See **Ceiling Connection** detail.
 - 2) Connect assembled header pieces together.
 - 3) Attach assembled header to assembled ceiling, using hex bolts.
See **Header Attachment** detail.
 - 4) Attach assembled ceiling and header to top of assembled backwall, using bolts.
 - 5) Attach panels, using A10 clamps.
See **Panel Clamp** detail.
 - 6) Attach sign to vertical [4A], using standoff barrels and caps.
 - 7) Connect graphic to Velcro on back of assembled header.

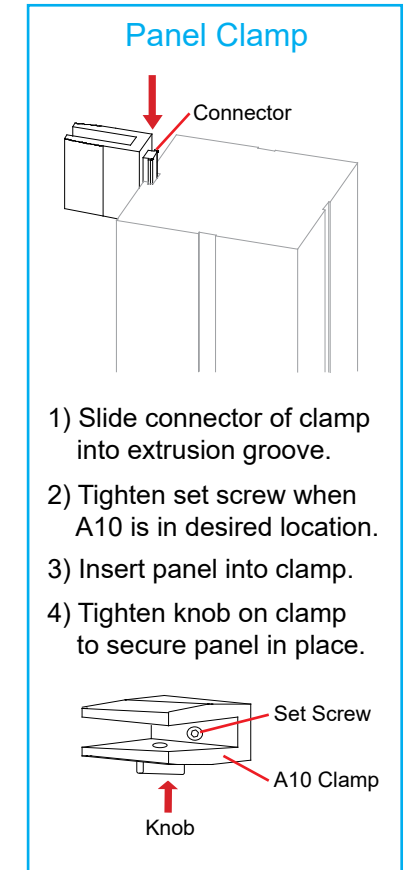
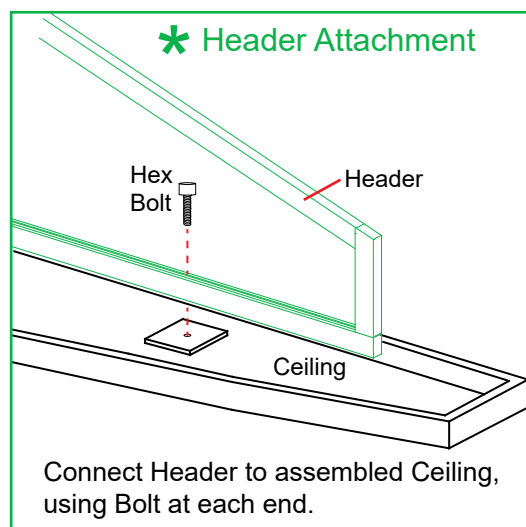
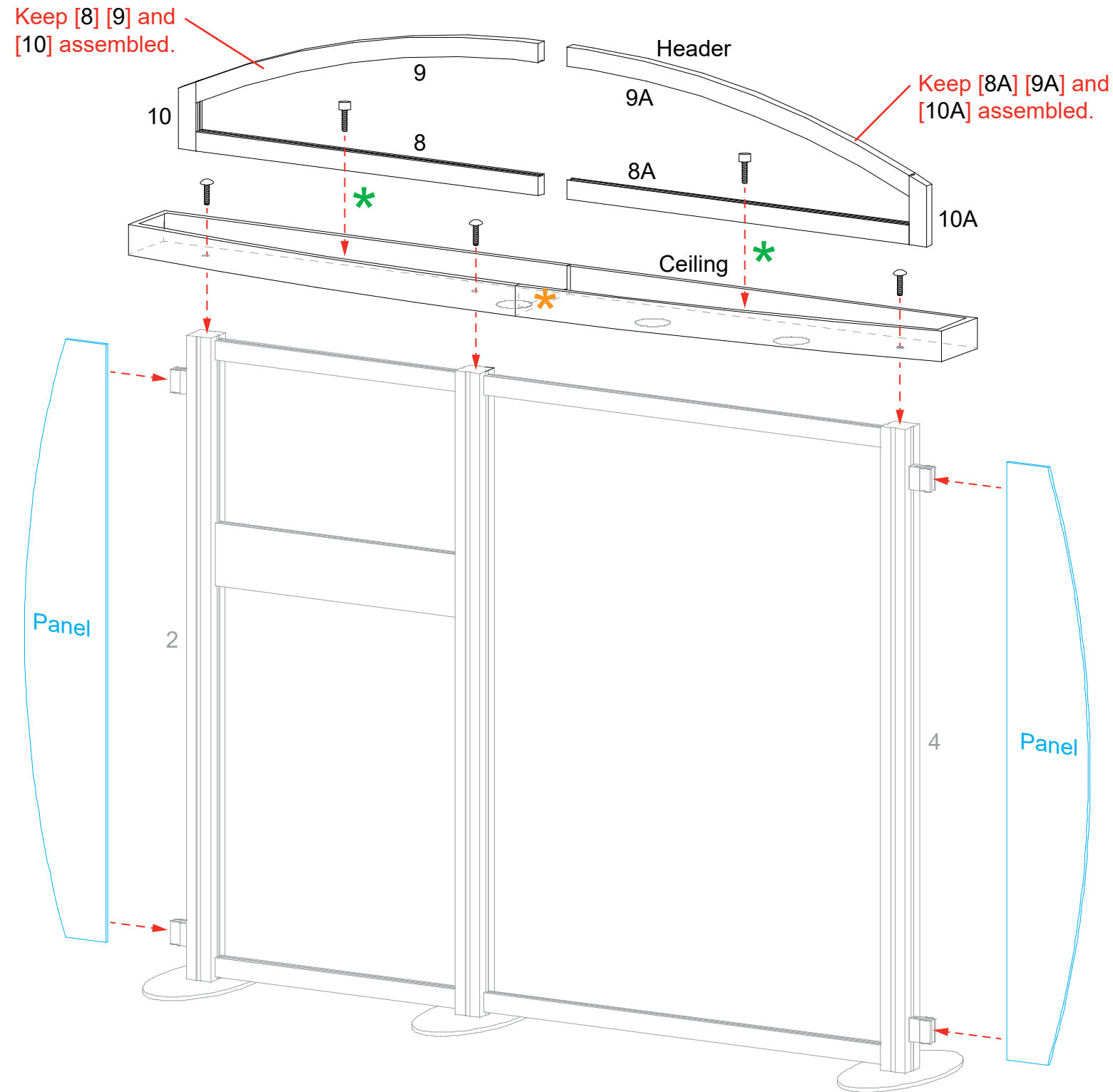

- Steps:
- 1) Attach monitor mount to horizontal [7]. See [Monitor Mount Attachment](#) detail.
 - 2) Attach sign to vertical [4], using standoffs and screw caps. See [Sign Attachment](#) detail.
 - 3) Attach literature holder to vertical [4]. See [Literature Holder Attachment](#) detail.

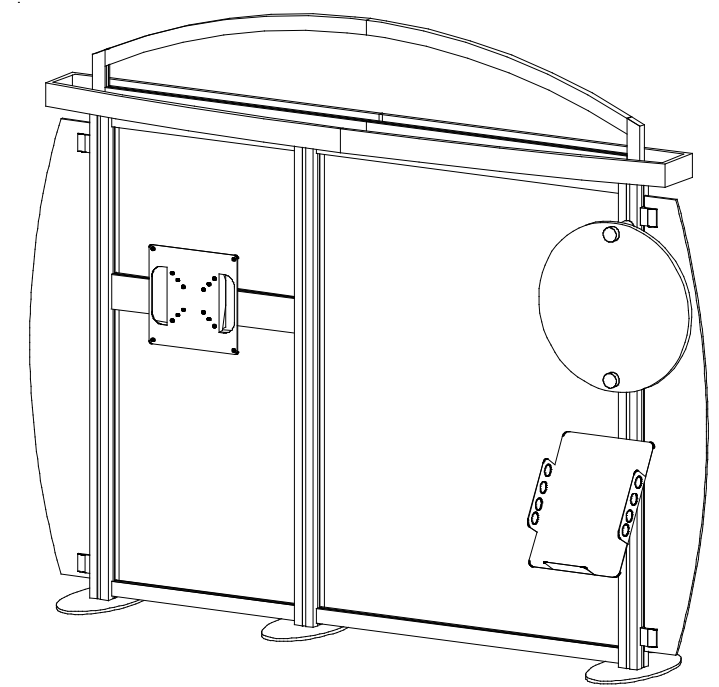

Completed Assembly

