

Item	Qty.	Description
--	1	62"w x 22.625"d x 40.5"h Reception Counter

- Steps:
 1) Attach Plex Counter Top to top of counter base.
 See **Plex Counter Attachment** detail.



When assembled

*** Plex Counter Attachment**

Attach stand-off barrels to primary counter top. Connect plex counter to primary counter top using screw caps.

The diagram shows a cross-section of the attachment process. A 'Screw Cap' is being inserted into a 'Standoff Barrel' which is already attached to the 'Counter Top'. The 'Plex Counter' is being lowered onto the 'Standoff Barrel'.

****DO NOT OVER TIGHTEN. PLEX WILL CRACK****

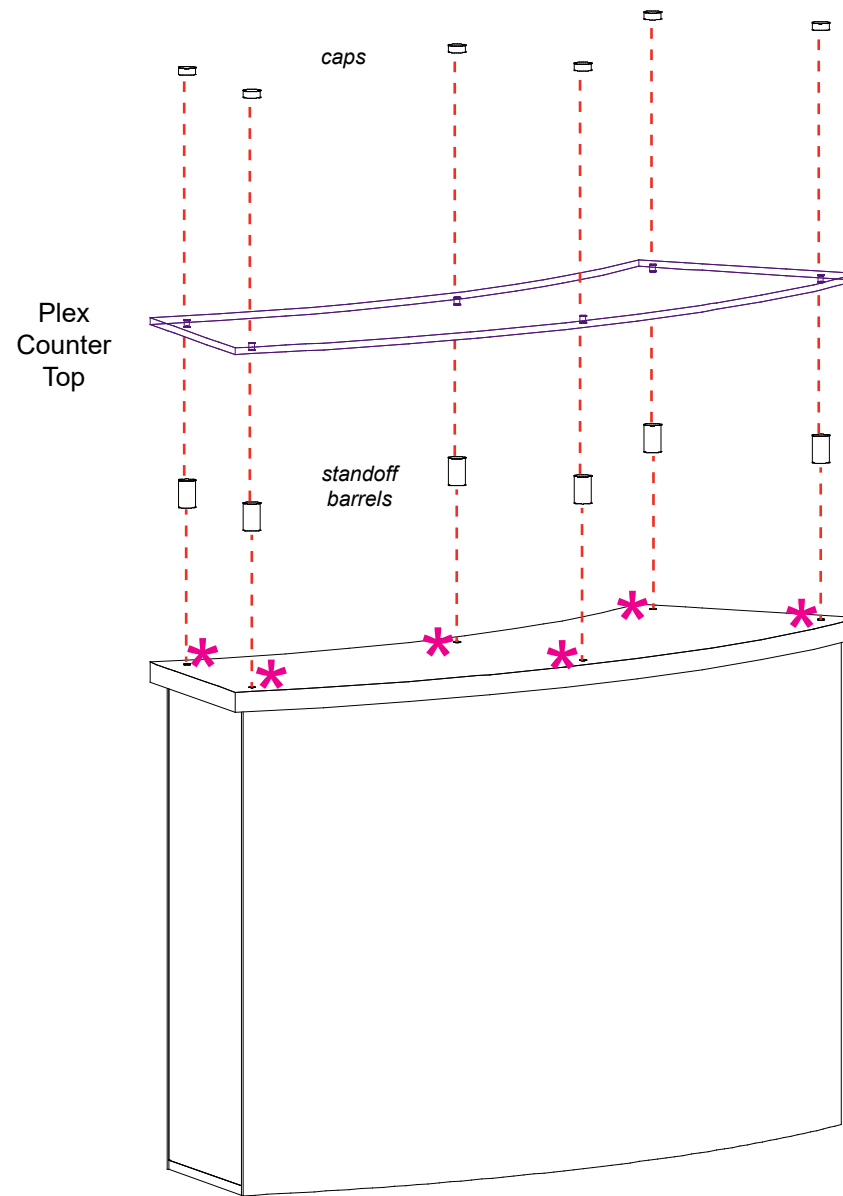

FRONT VIEW

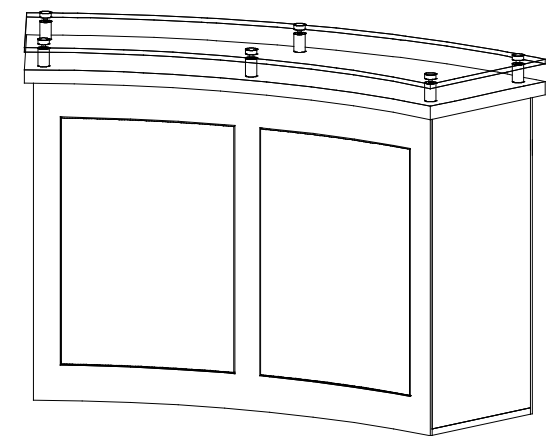

BACK VIEW

SETUP INSTRUCTIONS

General Setup Instructions

- Read entire setup instruction manual prior to unpacking parts and pieces.
- The setup instructions are created specifically for this configuration.
- Setup instructions are laid out sequentially in steps, including exploded views with detailed explanation for assembly.

Cleaning & Packing

- For Cleaning Metal, Plex, & Laminate Parts: Use a **MILD NON-ABRASIVE** cleanser and soft cloth/paper towel to clean all surfaces.
- Keep exhibit components away from heat and prolonged sun exposure.
- **Heat and UV exposure will warp and fade components.**
- Retain all provided Packing Materials. All provided packing materials are for ease of repacking & component protection.

Disassembly

- For loss prevention, tighten all set screws and locks during disassembly.

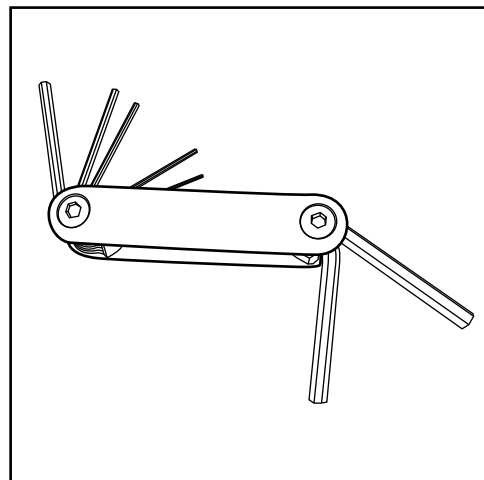

Hex Tool - Essential for Assembly

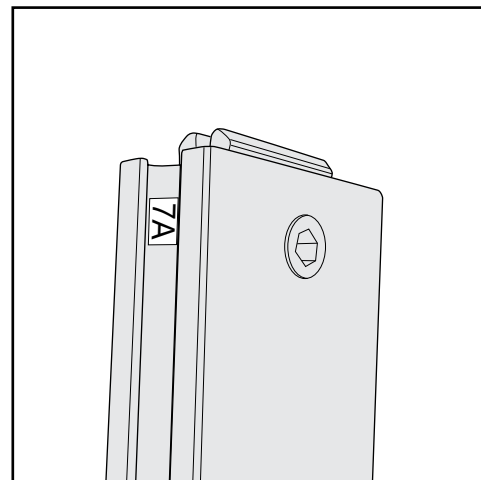

Part Identification - Numbering

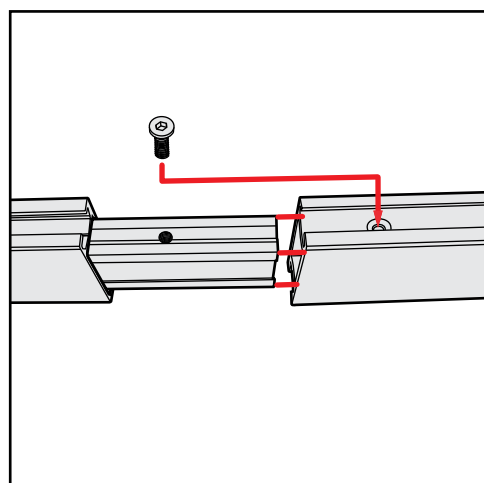

Spline Connection

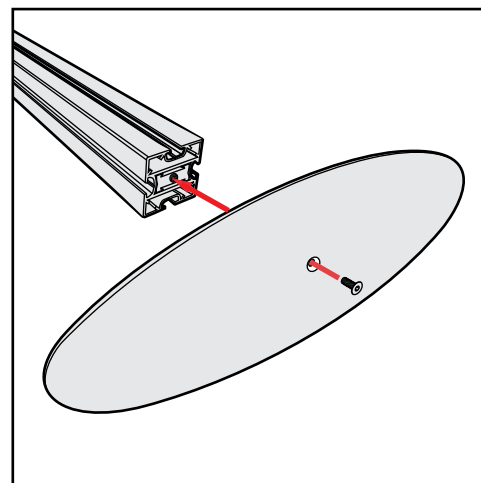

Base Plate & Extrusion Connection

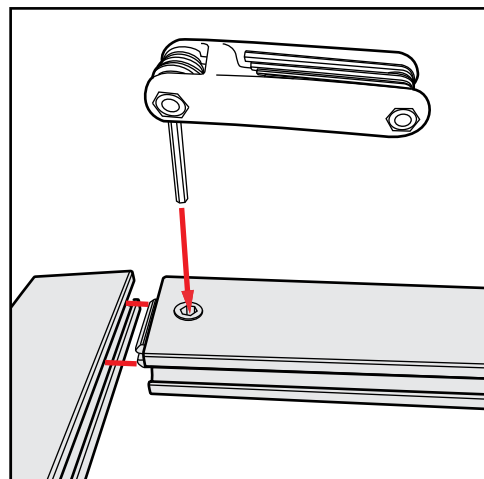

Extrusion & Lock Connection

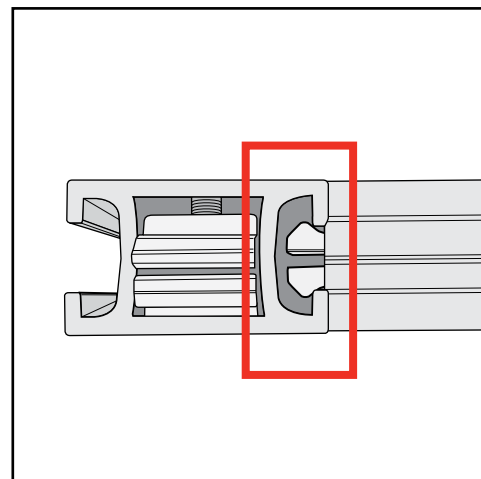

Engaged Lock



WARNING

DO NOT USE POWER TOOLS



LADDERS OR LIFTS
MAY BE REQUIRED

ALL CONNECTIONS MUST
BE TIGHTLY SECURED



CRATE PACKING